



2021 GENERAL CATALOGUE

Apparel Sewing Machines

DIGITALLY

Smart Solution

Digitalization of sewing machines redefines the traditional reliance on skilled operators in a sewing factory.

Digitalization of sewing technology allows for the improvement of quality, reproduction of optimum machine parameters, and optimize the time required for setup and maintenance of equipment.

Line up



DDL-9000C

Direct-drive, High Speed, Lockstitch Sewing System with Automatic Thread Trimmer



LZ-2290C

Semi-Dry head, Digital Zigzag Stitching Sewing System



LK-1900BN

Computer-controlled, High-speed, Bartacking Sewing System



LK-1903BN

Computer-controlled, High-speed, Button Sewing System



LBH-1790AN

Computer-controlled, High-speed, Buttonholing Sewing System



MS-1261A/DWS

High-speed, Feed-off-the-arm, 3-needle Double Chainstitch Sewing System (Digital workstation)



MEB-3900

Computer-controlled, Eyelet Buttonholing Sewing System (for jeans and cotton pants)



AMS-221F

Computer-controlled Cycle Machine with Input Function

PICTOGRAPH FOR FUNCTION

Needle		Feed		Stitch shape	
	2-needle		Bottom-feed		Zigzag stitching
	Organized split needle bar		Needle-feed		Lockstitch buttonholing
	3-needle		Bottom and variable top-feed		Eyelet buttonholing
	4-needle		Differential-feed		Bartacking
			Variable top-feed		Button sewing
			Horizontal-axis hook (large)		Belt-feed
			Horizontal-axis hook (3 fold-capacity)		X-Y drive
			Vertical-axis hook (large)		R-θ drive
					Button sewing with neck wrapping
					Belt-loop attaching
					Pocket welting
Stitch system		Non-Sewing		Function	
	Lockstitch		Tape bonding		Active tension
	Double chainstitch		Ultrasonic welding		Automatic thread trimmer
	Single-thread chainstitch		Press bonding		Cloth puller
	Pinpoint stitch		Testing machine		Cloth cutting knife
	Dry-head, Intelligent Direct-drive Sewing Machine		Dye Sublimation Printing		Stacker
			Direct to Garment		Digital Adjustments

1-NEEDLE, LOCKSTITCH MACHINES	
DDL-9000C	9
DDL-8000A	11
DDL-7000A	11
DDL-9000C-FMS PBN; DDL-8700-7; DDL-8700	12
DDL-5600N-7; DDL-5600N; DLU-5494N-7/IT-100A; DLU-5490N-7; DLU-5490N	13
DLU-5492N-7; DLN-9010A	14
DLN-5410N-7; DLN-5410N; DLN-6390-7; DLN-6390	15
DLM-5400N-7; DLM-5200N; DMN-5420N-7	16
DLD-5430N-7; DLD-5430N	17
1 Needle Lockstitch Machine Devices; Spare Parts Kit for the DDL8700-7; Spare Parts Kit for the DDL-9000C	18
2-NEEDLE, LOCKSTITCH MACHINES	
LH-4500C Series	20
LH-3528A-7, LH-3528A, LH-3578A-7 (with large hooks), LH-3578A (with large hooks)	21
LH-3568A-7, LH-3568A, LH-3588A-7 (with large hooks), LH-3588A (with large hooks)	22
OVERLOCK / SAFETY STITCH MACHINES	
MO-6700DA Series	24
MO6700DA-30P, MO-6800D	25
MO-6800D/BL Series, MO-6800S/BL Series, MO-6800S Series	26
MO-6900S Series, MO-6900R Series	27
MO-6900J Series, MO-6900G Series, MO-6900C Series	28
MO-6914C-BD6-307/X81028 (variable top-feed type)	29
Overlock and Safety Stich Devices	30
MO-6800 Consumable Kit	31
ZIGZAG STITCHING MACHINES	
LZ-2290C-7, LZ-2290C	33
LZ-2280A, LZ-2284A-7, LZ-2284A, LZ-2287A	34
LZ-2284C-7, LZ-271, LZ-391N	35
POST BED SEWING MACHINES	
DP-2100, LT-591	37
COVERSTITCH MACHINES	
MF-7500-U11; MF-7500-U11/UT; MF-7500D-U11; MF-7500D-U11/UT; MF-7500D/X83068; MF-7500-C11; MF-7500D-C11	39
MF-7500-E11, MF-7500D-E11, MF-7900-U11, MF-7900-U11/UT, MF-7900D-U11, MF-7900D-U11/UT	40
MF-7900-H11, MF-7900-H11/UT, MF-7900-H22,23, MF-7900-H22,23/UT, MF-7900D-H22,23, MF-7900D-H22,23/UT	41
MF-7900D-H24/UT, MF-7900D-H25/UT, MF-7900DR-H24 Series	42
MF-7900-E11, MF-7900-E11/UT, MF-7900D-E11, MF-7900D-E11/UT	43
MF-7900-E22, MF-7900-E22/UT, MF-7900-E23, MF-7900-E23/UT, MF-7200D-U10, MF-7200D-U10/UT, MF-7200D-K10, MF-7200D-K10/UT	44
UT51, UT52, UT53, UT55, UT57, UT59	45
SS11, PL12, PL13	46
MF-3620	47
CHAINSTITCH MACHINES	
MH-481-5, MH-481, MH-484-5, MH-484, MH-486-5, MH-380, MH-382	49
MS-1261A DWS, MS-1190, MS-1261	50
MS-3580, MP-200N	51
ML-111U, Chainstich Devices	52

BUTTON SEWING MACHINES	
LK-1903BN, LK-1903BNS, LK-1903BNB, LK-1903BNNS/BR35	54
LK-1903S	55
MB-1800A/BR10, MB-1800B, MB-1377, MB-1373	56
BUTTONHOLING MACHINES	
LBH-1790AN, LBH1790ANB	58
LBH-1790S, MEB-3200	59
MEB-3900	60
LBH-1790 Consumable Kits	61
BARTACKING MACHINES	
LK-1900BN, LK-1900BNB	63
LK-1900S, LK-1920, LK-1930	64
Bartacking Machine Devices	65
Bartacking Machines Consumable Kits	65
COMPUTER-CONTROLLED CYCLE MACHINES	
AMS-221F-2516, AMS-221F-3020	67
AMS-210EN-1510, AMS-210EN-1306, AMS-210EN-1510, AMS-210EN-2210, AMS-210EN-1306, AMS-210EN-2210, AMS-221EN-2516, AMS-221EN-2516, AMS-221EN-3020	68
AMS-221EN-HS3020/7200, AMS-221EN-TS3020	69
AMS-221EN-TS3020/X90004, AMS-224EN-4530, AMS-224EN-6030	70
AMS-221EN-SS3020/72001764	71
AMS-224EN6030/X7910, AMS-221EN2516/X7910, AMS-221EN/JEUX0043, AMS-221EN/X7910/JEUX0043, AMS-224EN/JEUX0043, AMS-224EN/X7910/JEUX0043	72
PS-700, PS-800-12080, PS-800-8045	73
Computer-controlled Cycle Machines Parts	74
AUTOMATIC MACHINES	
APW-895NS, APW-895NL, APW-896N	76
AP-876, AP-874, AB-1351	77
MOL-254, AMB-289	78
LBH-1796AN	79
AC-172N-1790, ASN-690	80
AE-200ALA, AE-200ALD, WS-8700	81
Automatic Machines Parts	82
SEAM SEALING AND ULTRASONIC MACHINES	
JEUX-6510 F3+, JEUX-6510 F3, JEUX-6510 S3+	84
JEUX-AI-001	85
JEUX-AI-107, JEUX-AI-008	86
QHP-A05, QHP-A08, LHP-PP1	87
JEUX-7510, LWU-3015	88
JEUX-US-501	89
JEUX-CS-658	90
JEUX-CS-652	91
INDUSTRIAL PRINTERS	
Sure Colour F-2100, Sure Colour F-6200	93
Sure Colour F-7200, Sure Colour F-9300	94
OTHERS	
SC-922/M51N, SC920/M92	96
SV-71, SV-72, SV-82, SV-520	97
Motors and Control Boxes, JEUX-0021	98
SOFTWARE	
JaNets	100
PM-1	101
PM-3	102



Juki Central Europe (JCE), a subsidiary of Juki Corporation, was established in 2005 as the official body coordinating sales and logistics across twenty European countries as well as Russia, North Africa and Turkey. From the company offices in Warsaw, Poland; sales, marketing, logistics and technical support services are coordinated for the entire extended European market-place. The company's strengths are leveraged through an extensive distributor network that has been established over the years, offering the shared knowledge and expertise of industry leading experts in the sewing sector.

Juki Central Europe's different office in Moscow, Minsk and Turkey, as well as Juki Italia S.p.A, again add to our extensive network supporting and maintaining the Juki brand across the continent and beyond.

Juki offers an extensive line of industrial sewing machines for the apparel industry – ranging from Lockstitch, Overlock and Coverstitch machines, to electronic bartackers and automated sewing systems. Our machines have also become renowned in the non-apparel sector, supplying such industries as automotive, upholstery, marine, industrial fabrics, footwear, leather products and home textiles.

Software solutions such as **JaNets (Juki Advanced Network Systems)** is the next frontier of sewing innovation and aims to bring your production into the future with interlinked machines and data to make analytical decisions.

As well as our extensive range of high quality industrial sewing machines **Juki** produce machines for the semi-professional and home-use market with our home sewers and surgeons establishing themselves as some of the most popular and reliable in the market.

We are very proud of our historically strong distribution network across Europe and throughout the rest of the world. From **Juki Central Europe's offices in Warsaw** and through our representative offices we are able to serve the entire extended European market and North Africa. Through our carefully selected distributors we are able to combine knowledge and specific geographical market experience to ensure the best sewing solutions are available to

customers. Leveraging both our own expertise as well as that of our distributors we are able to provide insights and assistance that can improve end users productivity and quality.

Here in **Juki Central Europe** we constantly have one eye on the future and are looking to improve not only our own business but that of our customers and anyone who uses a **Juki** sewing machine. Our products are developed and manufactured with a consumer viewpoint in-mind at all times and it is our goal to build strong, lasting customer relationships. We will continue to provide products and services by taking our customers' needs and desires into account, by treating our customers as partners, through which we will create value together.

Juki was founded in 1938 when nearly 900 independent machinery manufacturers came together to form the "TOKYO JUKI MANUFACTURERS ASSOCIATION." It wasn't until 1943 that this association was reorganized into a joint stock corporation. In this time Juki focused on other production types but in 1947 we produced our first sewing machine for the household market. This was followed by the first Juki industrial sewing machine in 1953 and decades of industry dominance thereafter. Juki has been at the forefront of sewing machine innovation over its lifetime with many of our advancements being adopted industry wide. To name just a few of our more famous improvements: the single-axis rotational thread take-up (1957), automatic Thread Trimmer (1969), pick-and-placer (1987), automatic bobbin thread feeder (1997), multifunctional machine digitalization (2015). This is just one milestone for Juki and we look forward to continuing our journey far into the future.

WHAT IS A SMART FACTORY?

IT IS VISUALISED

IT IS CONNECTED



Factory management



Production Line Control



Operator Motivation



Connected Supply Chain



Connected factory



Connected Sewing Line

JUKI SOLUTIONS

01 AUTOMATIZATION



Robot Sewing System

02 DIGITALIZATION



Digital Control

03 NETWORKING



Production Data Collection



Automatic Guided Vehicle



Two-way Communication



Production Output Machine Operation Rate

JUKI GENUINE SPARE PARTS

Juki Genuine spare parts are made to the highest possible standard and are created with only the best raw materials. The shape, dimension, finishing and materials of all Juki genuine parts are rigorously tested to ensure end users have a product that will be reliable and durable even under heavy use. Each genuine spare part is created based in the specification and accumulated experience of Juki technical staff who work to create the machine the part will be used for in the first place.

The proper material for each part is specially selected and tested before being standardized; this means a genuine part maintains the exact quality and accuracy no matter the piece. Juki genuine parts are also inspected and compared against the pre define specification outlined to ensure the best possible performance.



The effects of using counterfeit parts in a Juki machine include: poor sewing, decreased productivity, increased costs, reliability of factory output questioned and lose of Juki guaranty and warranty. Non-genuine parts are not put through the same conditioning and testing resulting in a subpar material that will result in poor sewing.

A difference in the parts shape and finishing can drastically effect the machines operation and result in skip stitches among many other issues. One of the biggest consequences of using none genuine spare parts is a decrease in productivity. These counterfeit parts will cause more



machine problems depending on the specific part in question e.g. skip stitches, slower feeding of the material and inconsistent stitches.

As a result, any investment saved on the individual part will be counter-acted by the loss of money from the fall in productivity as well as wasted time and material. Also more machine down time due to problems caused by none genuine parts will result in an increased cost for any factory. Costlier than the wasted time and material mentioned above is the effect poor production can have on a factories reputation.



THE REAL COST OF NOT USING NON-GENUINE PARTS



Juki Genuine spare parts are tested against rigorous standards to ensure the shape, size and materials used meet exact specification

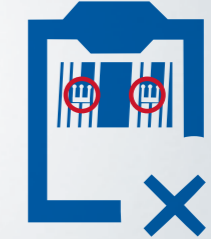

Incorrect shape can result in poor sewing and thread breakage



FACTORY A USES JUKI GENUINE HOOKS

FACTORY B USES GENERIC HOOKS



JUKI HOOK COSTS €40

GENERIC HOOK COSTS €5

That's a saving of €35.... or is it?

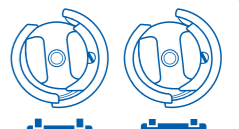

12

6

A Juki hook has a durability of 12 months and a generic hooks only lasts 6



If both factories have 30 Juki sewing machines it means that factory B is still saving €900 a year



X 30

€1200/Y



€300/Y

If it takes 57.6 seconds to make one t-shirt that is 500 a day



57,6s.

If thread breakage increases to an average of 1 time per 10 minutes over a full day then processing time per unit is now 58.753 seconds



58,752s. 490

BUT THERE IS MORE



1€

0,95€

If after a time of producing lower quality products factory may only get a reduce price for its t-shirts

If one t-shirt is sold €1 then factory B is losing €10 per day or €2800 a year

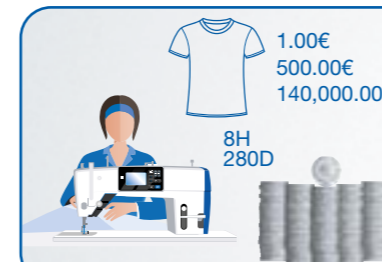

1.00€
500.00€
140,000.00€
8H
280D

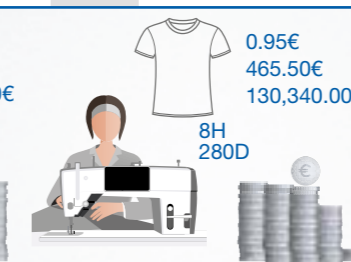

0.95€
465.50€
130,340.00€
8H
280D

The real cost over a year of using generic spare parts is 11,560€



Please scan here to see a video



1-NEEDLE, LOCKSTITCH MACHINES

DDL-9000C

Direct-Drive, High Speed, Sewing System with Automatic Thread



NEEDLE-THREAD ACTIVE TENSION

Needle thread tension which matches sewing conditions given can be set on the operation panel and stored in memory.

NFC TRANSFER OF DATA

NFC technology allows parameters to be easily transferred to other machines saving time compared to manual adjustments.

DIGITAL CONFIGURATION

All machine parameter can be adjusted and saved via the operations panel. Meaning exact setting every time.

ACTIVE PRESSER FOOT PRESSURE

The material thickness is automatically detected and the height of the presser foot is automatically raised or lowered.

DIGITAL FEED MECHANISM

The feed dog height can be adjusted with ease according to the material fabric of product to be sewn.

CUSTOMIZABLE HAND SWIT

20 different functions can be programmed through the operation panel for us on the hand switch. Only the most important functions for you are easily accessible.

REVERSE FEED LEVER

Provided as standard

Adoption of the needle-thread active tension

Needle tension is digitally controlled

Needle thread tension which matches sewing conditions given can be set on the operation panel and stored in memory. The needle thread tension adjustment needs experience. However, for this sewing machine, thread tension data stored in memory is reproducible, thereby reducing the setup time when the product to be sewn is changed. Example: Needle-thread active tension demonstrates its effectiveness in the topstitching process.

For welting shoulders of a difficult-to-sew material, uniform stitches can be produced continuously by appropriately changing the sewing conditions even if the right and left material fabric differ in texture grain.



Quality product

Defective product

The active presser foot pressure mechanism demonstrates its effectiveness in prevention of stitch gathering and loose stitches.

The needle thread tension, presser foot pressure, pitch, feed locus and feed dog height can be totally changed to link their adjustments appropriately.

1-NEEDLE, LOCKSTITCH MACHINES

Juki's new flagship lockstitch machine has been digitalized to allow easier operation and streamlined programing. The DDL-9000C series is available in two types: Full Digital and Digital

Please scan here to see a video



Machine information continues on the next page

1-NEEDLE, LOCKSTITCH MACHINES



DDL-9000C Series

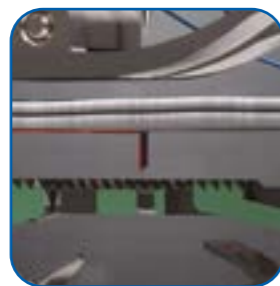

Conventional product



DDL-9000C Series



Conventional product

Double-edge drive rotary knife system is adopted. The double edges of the rotary knife intersect with each other directly under the needle entry point to trim the thread.



Management, browsing and editing of data can be carried out via application software. Data on sewing machine adjustments made according to the product to be sewn can be transferred to an Android tablet or phone via the Juki Smart App in contactless mode (NFC). This enables quick check for uniform settings as well as confirmation of conditions of sewing machines in a sewing line, thereby facilitating setup changes. The operation panel is also provided as standard with a USB port. Data management and software update can be carried out with ease using a USB thumb drive.



Full Colour Touch Panel (Full-Digital)



Black and White Liquid crystal screen (Digital)

	Full-digital model	Digital model
Digital feed (Horizontal direction)	•	•
Digital feed (Vertical direction)	•	•
Digital presser foot	•	x
Active tension	•	x
Support to an Android tablet	•	•
Network	•	(Support through an Android tablet)
Shorter remaining thread	•	•
Colour touch panel	•	X

Model name	DDL-9000C-FMS	DDL-9000C-FSH	DDL-9000C-SMS	DDL-9000C-SSH
Type	Full Digital Type		Digital Type	
Application	Medium-weight	Heavy-weight	Medium-weight	Heavy-weight
Lubrication	Semi-dry	Minute-quantity lubrication	Semi-dry	Minute-quantity lubrication
Max. sewing speed	5,000 sti/min*1	4,500 sti/min*2	5,000 sti/min*1	4,500 sti/min*2
Hand switch	Provided as standard (At the time of shipment: Hand switches are assigned respectively with the touch-back switch function and the one-touch changeover switch function.)			
Max. stitch length	5 mm			
Thread trimming method	Double-edge rotary system			
Needle bar stroke	30.7 mm	35.0 mm	30.7 mm	35.0 mm
Feed dog height	0.8 mm	1.2 mm	0.8 mm	1.2 mm
Needle thread tension	Active tension		Spring type	
Presser foot pressure	Electronic control		Spring type	
Lift of the presser foot	By hand: 5.5 mm, By knee: 15 mm Auto: 1st stage 5.0 mm (*0.1~8.5 mm), 2nd stage 8.5 mm (*8.5mm~13.5mm)* Adjustable on the operation panel			
Needle*3	DBx1-DPX5(#11) #9~18(Nm65~110)	DBx1-DPX5(#21) #20~23(Nm125~160)	DBx1-DPX5(#11) #9~18(Nm65~110)	DBx1-DPX5(#21) #20~23(Nm125~160)
Bobbin thread winder	Built in the top of machine head (provided with the bobbin thread retaining plate)			
Lubricating oil	JUKI New Defrix Oil No. 1 or JUKI CORPORATION GENUINE OIL 7 (equivalent to ISO VG7)			

sti/min stands for "Stitches per Minute".

*1 Stitch length of 4.00 mm or less: 5,000 sti/min; Stitch length of 4.05 - 5.00 mm: 4,000 sti/min.

*2 Stitch length of 4.00 or less: 4,500 sti/min; Stitch length of 4.05 - 5.00mm: 4,000 sti/min.

*3 Differs on a destination-by-destination basis

DDL-8000A

Direct-drive, High Speed, 1-needle, Lockstitch Machine with Automatic Thread Trimmer

The DDL-8000A is the first in the line of Juki's new "Simply Smart" series of machines. This new model comes with internally built motor and intuitive operation panel.



DDL-8000A

Model name	DDL-8000A-SMSNBAKN	DDL-8000A-SSHNBAKN
Application	Medium-weight	Heavy-weight
Lubrication	Semi-dry	Minute-quantity lubrication
Max. sewing speed	5,000 sti/min	4,000 sti/min
Max. stitch length	5 mm	5 mm
Lift of the Presser Foot	By hand: 5.5 mm, By knee: 15 mm, Auto: 8.5 mm	
Needle	DBx1(#11)#9-18 (Nm65-110)	DBx1(#21)#20-23 (Nm125-160)

DDL-7000A

Direct-drive, High Speed, 1-needle, Lockstitch Machine

The DDL-7000A is an energy saving lockstitch machine with an internally built direct driver servo motor. With automatic thread trimming and the seam quality Juki is known for this model while simple will deliver time and time again.



DDL-7000A

Model name	DDL-7000A
Application	S: Light to midium weight H: Heavy weight
Max. sewing speed	5,000 sti/min*
Max. stitch length	5 mm
Presser Foot	By hand: 5.5mm, By Knee: 13mm
Needle	DBx1(#21)#20-23 (Nm125-160)

1-NEEDLE, LOCKSTITCH MACHINES

DDL-9000C-FMS PBN

Semi-dry head, Direct-drive, 1-needle Lockstitch Sewing System with Automatic Thread Trimmer (Bird's nest prevention type)

The newly-developed model totally eliminates bird's nests (thread clumping) at the start of sewing, which is a common factor when using sewing machines with a thread trimmer. As well as this the DDL-9000C-FMS/PBN shortens the remaining thread at the end of the seam, meaning that manual cutting is not needed. DDL-9000C/PBN has digitalized machine adjustments so manual adjustments are not needed.

Model name	DDL-9000C-FMS/PBN
Application	Medium-weight
Lubrication system	Semi-dry
Max. sewing speed	4,000 sti/min
Max. stitch length	4 mm
Lift of the Presser Foot	Auto : 1st stage 5.0 mm (*0.1~8.5mm), 2nd stage 8.5 mm (*8.5mm~13.5mm) *Adjustable on the operation panel
Needle	DBx1-DBx5 (#11) #9~#18 (Nm65~110)



Conventional lockstitch machine with automatic thread trimmer



Cbrid's nest prevention type

DDL-5600N-7

DDL-5600N

1-needle, Lockstitch Machine with Double-capacity Hook

The machine is provided with a double-capacity hook which is suited for the sewing of heavy-weight materials and jeans. The maximum stitch length is 8mm increasing the applications that require longer stitch lengths (i.e. bags).



DDL-5600N-7

Model name	DDL-5600NJ-7, 5600NJ	DDL-5600NL-7, 5600NL
Application	Jeans	Heavy-weight
Max. sewing speed	4,000 sti/min	3,000 sti/min
Max. stitch length	5 mm	8 mm
Presser foot	By knee: 13 mm	
Needle	DBx1 (#21) #20~#23, 134 (Nm130)	
Thread Trimmer	Yes / No	



DDL-8700-7

DDL-8700

1-needle, Lockstitch Machine

By thoroughly investigating and modifying the sewing mechanisms in order to achieve low-tension sewing, the machine flexibly responds to various kinds of materials and produces beautiful seams of consistent quality.



DDL-8700-7

Model name	DDL-8700-7	DDL-8700	DDL-8700H-7, 8700H
Application	Medium-weight		Heavy-weight
Max. sewing speed	5,000 sti/min	5,500 sti/min	4,000 sti/min
Max. stitch length	4 mm	5 mm	
Lift of the presser foot	By knee: 13 mm		By knee: 13 mm
Needle	DBx1(#14) #9~#18, 134 (Nm90)		DBx1(#21) #19~#23, 134 (Nm130)
Thread Trimmer	Yes	No	Yes / No

DLU-5494N-7/IT-100A

(shirring control device)

1-needle, Bottom and Variable Top-feed, Lockstitch Machine

With its programmable variable top feed, the machine achieves high-quality shirring with consistency. The machine enables even inexperienced operators to perform shirring operation smoothly and easily.

DLU-5490N-7

DLU-5490N

With its bottom and variable top-feed mechanism, the machine widely adapts to diversified applications and helps promote the production of upgraded-quality products while increasing efficiency.



DLU-5494N-7/IT-100A

Model name	DLU-5494N-7/IT-100A	DLU-5490N-7, 5490N
Max. sewing speed	4,000 sti/min	4,500 sti/min
Max. stitch length	5 mm (forward), 3 mm (backward)	5 mm
Max. top-feed amount	8 mm (top feed amount varies depending on the type of gauge)	8 mm
Presser foot	By knee: 13 mm *When using auto-lifter AK85: 9 mm	13 mm
Needle	DBx1 (#14), 134 (Nm90)	DBx1 (#14), 134 (Nm75)



Please scan here to see a video

1-NEEDLE, LOCKSTITCH MACHINES

DLU-5492N-7

1-needle, Bottom and Variable Top-feed, Lockstitch Machine with Automatic Thread Trimmer (for topstitching shirt collars)

With the digitally controlled material edge sensor and cloth guide, the sewing machine is able to sew topstitches on collars while keeping the constant edge width.

Model name	DLU-5492N-7 / IT-100F
Maximum sewing speed	4.000 sti/min* (normal operation: 2.500 sti/min)
Stitch length	1.3-3.5 mm
Maximum top feed amount	8 mm (differs with the gauge)
Needle bar stroke	30.7 mm
Lift of presser foot	Manual: 5.5 mm / By air: 10.0 mm
Needle (attached at the time of shipment)	DBx1(#11)#9-#18
Hook	Automatically-lubricated full-rotary hook
Lubricating method	Provided as standard
Lubricating oil	JUKI New Defrix Oil No. 1 (equivalent to ISO VG7)



DLU-5492N-7

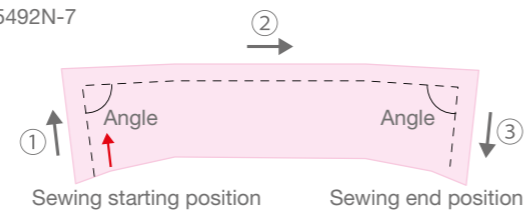

Thanks to the digital stitch guide, handling of material at the corner sections of a collar is carried out with ease.

DLN-5410N-7

DLN-5410N

1-needle, Needle-feed, Lockstitch Machine

The machine produces seams with accurate stitch length and prevents slippage of the upper fabric. The machine ensures beautiful seam quality free from stitch gathering, even when a hard-to-feed material is used.

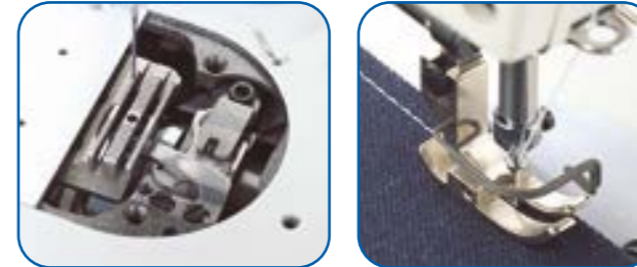

DLN-5410N-7

Model name	DLN-5410N-7, 5410N	DLN-5410NH-7, 5410NH	DLN-5410NJ-7
Application	Light- to medium-weight	Medium- to heavy-weight	Jeans
Max. sewing speed	5.000 sti/min	4.000 sti/min	
Max. stitch length	4 mm	4.5 mm	
Presser foot	By knee: 13 mm		
Needle	DBx1 (#14), 134 (Nm90)	DBx1 (#21), 134 (Nm130)	
Thread Trimmer	Yes / No		Yes

DLN-9010A

Direct-drive, High-speed, Needle-feed, Lockstitch Machine

Similar to the features of the DDL-9000B, this machine has a direct drive motor, 31cm distance from needle to the machine arm, and a micro lifter included as standard.



DLN-9010A

Model name	DLN-9010A-SS	DLN-9010A-SH
Application	Light - to medium-weight	Heavy-weight
Max. sewing speed	5.000 sti/min	4.000 sti/min
Max. stitch length	4.5 mm*	4.5 mm
Presser foot	By knee: 15 mm (max.), Auto: 10 mm	
Needle	DBx1 (#14) #9-#18, 134 (Nm90) Nm65-Nm110	DBx1 (#21) #20-#23, 134 (Nm130) Nm120-Nm160

* The max. sewing speed should be set at 4.000 sti/min or less when the machine is used with a stitch length of more than 3.5mm.

DLN-6390-7

DLN-6390

High-speed, Cylinder-bed, 1-needle, Needle-feed Lockstitch Machine with Large Hook

The cylinder-bed lockstitch machine with a thread trimmer is designed for hemming the bottom of jeans, casual pants and work uniforms.

Model name	DLN-6390-7	DLN-6390
Max. sewing speed	5.000 sti/min	
Stitch length	Standard gears: 3.2 mm (2.8 mm) / Supplied gears: 2.3 mm, 3.6 mm / Optional gears: 2.1 mm, 2.5 mm, 4.2 mm (utilized by changing pitch conversion gears)	
Presser foot	Max. 14 mm	
Binder open / close type	Driven by air cylinder	Manual type
Cylinder-bed diameter	180 mm	
Needle	UY180GVS Nm140 range of use: Nm90-Nm150 (equivalent to #14-#22.5)	
Thread Trimmer	Yes	No



DLN-6390-7



1-NEEDLE, LOCKSTITCH MACHINES

DLM-5400N-7

DLM-5200N

1-needle, Lockstitch Machine with Vertical Edge Trimmer

The knife is sharp enough to cut any type of material. The one-touch utility knife lever enhances the comfort of operation.

Model name	DLM-5400N-7
Max. sewing speed	4,500 sti/min
Max. stitch length	4 mm
Presser foot	By knee: 10 mm
Needle	DB×1 #16~#23
Thread	DB×1 (#14) #9~#18, 134 (Nm90)
Thread Trimmer	Yes

Model name	DLM-5200N
Max. sewing speed	4,500 sti/min
Max. stitch length	5 mm
Presser foot	By knee: 10 mm
Needle	DB×1 (#14), 134 (Nm90)



DLM-5400N-7



DMN-5420N-7

DMN-5420N-7

1-needle, Needle-feed, Lockstitch Machine with Vertical Edge Trimmer

The machine is a needle-feed type. The knife is sharp enough to cut any type of material.

Model name	DMN-5420N-7
Max. sewing speed	5,000 sti/min
Max. stitch length	5 mm
Presser foot	By knee: 10 mm
Needle	DB×1 (#14) #9~#18, 134 (Nm90)
Max. thickness of the material to be cut	4 mm
Thread Trimmer	Yes

DLD-5430N-7

DLD-5430N

1-needle, Differential-feed, Lockstitch Machine

With its highly reliable bottom-differential-feed mechanism, the machine promotes the production of upgraded-quality products while increasing efficiency.

Model name	DLD-5430N-7, 5430N
Max. sewing speed	4,500 sti/min
Max. stitch length	5 mm
Max. top-feed amount	Shirring 1:1.5 (max. 1:3*), Stretching 1:0.5
Needle bar stroke	30.7 mm
Presser foot	By knee: 13 mm
Needle	DB×1 (#14), 134 (Nm90)
Thread Trimmer	Yes / No



DLD-5430N-7

1-NEEDLE, LOCKSTITCH MACHINES

1 Needle Lockstitch Machine Devices

Item	Descriptions	Item Number
AK85	Footlifter DDL8700-7	GAK850010AA
AK85B	Footlifter for DDL900A, DDL900B	40140416
AK85J7R	AK85J7R Footlifter for DDL Generic	AK85J7R
Microlifter	Micro lifter for DDL series	11243763
Microlifter	Micro lifter for DDL9000B	40056622
Microlifter	Micro lifter for DDL9010A	23611056
Bobbin Monitor AE4	Bobbin Thread Monitor AE4 for DDL series	GAE040000A0
Bobbin Monitor AE5	Bobbin Thread Monitor AE4 for DDL5410NJ-7	GAE050000A0
Bobbin Monitor AE8	Bobbin Thread Monitor AE8 for DDL9000 DLN9010	GAE080000A0
Second Thumb Sw	Additional Thumb Switch DDL9000B	23632656
Second Thumb Sw	Additional Thumb Switch DLN9010A	40000380

Spare Parts Kit for the DDL8700-7

DDL-8700-7		Description	Quantity
Kit P/N	40164792	PROMOTIONAL_PARTS_ASSY	1 set
Construction Part Number	22921605	Thread take-up spring	2
	40065552	Throat plate screw	1
	11038650	Hook ASM	1
	22932909	Bobbin	3
	22916555	Oil seal screw ASM	1
	22906309	Needle bar thread guide	1
	SS708051OTP	Screw 1/8-44 L=4.5	1
	11040052	Moving knife ASM	1
	22947808	Knife thread guide	1
	D2406555DOH	Counter knife	2

Spare Parts Kit for the DDL-9000C

DDL-9000C		Description	Quantity
Construction Part Number	SM2040955TP	Screw M4 L=8.5	1
	26261602	Bobbin spring	1
	SS4080620TP	Screw 1/8-44 L=6	2
	RO048190100	Rubber ring	1
	SS6090670TP	Screw 9/64-40 L=6	1
	SS7091110TP	Screw 9/64-40 L=10.5	1
	SM2040750TP	Screw M4 L=7.4	1
	40000344	Lubricating inlet cap	1
	22964001	Bobbin (A)	1
	SM6051400SP	Screw	1
	40172485	Knife unit	1
	11038759	Bobbin case asm.	1
	11038650	Hook asm.	1
	40172417	Btw_lever	1





2-NEEDLE, LOCKSTITCH MACHINES

2-NEEDLE, LOCKSTITCH MACHINES

LH-4500C Series

Semi-dry head, 2-needle Lockstitch Sewing System

Seam quality is improved by introducing the separately-driven right and left active tension mechanisms. The needle thread tension is automatically corrected according to the sewing speed. Consistently good seam quality is, therefore, achieved regardless of changes in sewing speed. The needle thread tension is automatically corrected according to the remaining amount of bobbin thread. Seam quality is, therefore, stabilized even when the remaining amount of bobbin thread has reduced.

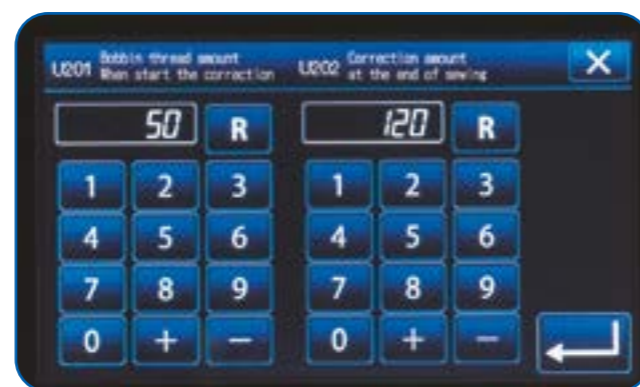
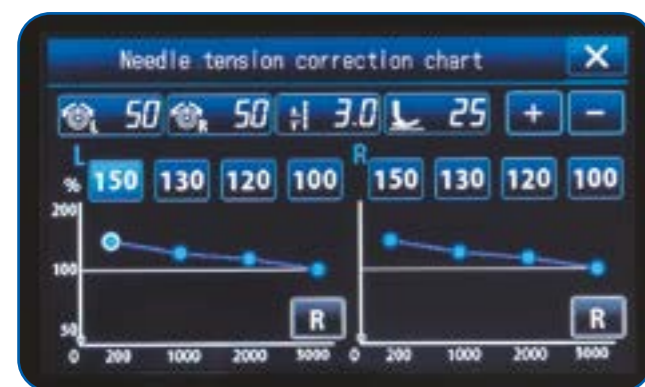

Model name	LH-4578CFF	LH-4578CFG-7	LH-4588CFG-7
Application	Foundation	Jeans and heavy-weight materials	
Corner stitching	Not provided	Provided	
Lubricating system	Semi-dry / Hook section: Minute-quantity lubrication (tank system)		
Feed system	Needle feed		
Max. sewing speed	3,000 sti /min		
Max. stitch length	4 mm	7 mm	
Thread take-up lever	Slide type		
Needle bar stroke	33.4 mm		
Needle thread tension	Independent right and left active tension mechanism		
Lift of the presser foot (max.)	13 mm		
Needle	DP x 5 #10 (#9 - #16)	DP x 5 #21 (#16 - #23)	
Hook	Vertical-axis large hook (1.8 - fold)		
Free space under the arm	120 mm (height) x 266 mm (distance from machine arm to needle) x 87 mm (height of the jaw section)		
Lubricating oil	JUKI New Defrix Oil No.1 (Equivalent to ISO VG7)		

LH-3528A-7

LH-3528A



LH-3578A-7

LH-3578A

(with large hooks)

(with large hooks)



This is the cutting-edge model 2-needle sewing machine which comes with substantially enhanced mechanisms such as the direct drive mechanism, semi-dry head, new thread tension control mechanism and improved oiling system. All models of the LH-3500A Series are provided with a semi-dry head to eliminate staining with oil from the frame (the needle bar part). The LH-3528A can be switched to bottom feed to further improve the stitch quality.

*A thread tension control mechanism has been developed for each type of sewing machine in order to achieve the best-suited thread tension for its purpose.
*Two selectable new-method oiling mechanisms.



NEEDLE TENSION
The needle tension controller allows for quality seams free from puckering and irregularities.

OPERATIONAL PANEL
The CP-18A and CP-180A operational panels are both available for this model. Measurements of bobbins, output functions (target vs results) and operation (pitch time, process machining time).

MICRO-LIFTER
The presser foot can be lifted by adjusting the eccentric pin located in the presser lifter lever; improving sewing shaggy and elastic fabrics.

THREAD GUIDE
The wire-type needle bar thread guide has been adopted for light-weight materials and foundations without puckering or irregular stitches.

Please scan here to see a video



Model name	LH-3528A-7	LH-3528A	LH-3578A-7	LH-3578A
Application	A: Light-weight, F: Foundation, S: Medium-weight, G: Jeans and heavy-weight		G: Jeans and heavy-weight	
Max. sewing speed	3,000 sti/min			
Max. stitch length	5 mm (F type: 4 mm)		5 mm	
Needle gauge	3.2~34.9 mm (1/8"-1-3/8")	2.4~38.1mm (3/32"-1-1/2")	3.2~25.4 mm (1/8"-1")	3.2~38.1 mm (1/8"-1-1/2")
Presser foot	By knee: 13 mm, By hand: 7 mm			
Needle	A: DPx5 (#9) #9-#16 F: DPx5 (#10) #9-#16	S: DPx5 (#14) #9-#16 G: DPx5 (#21) #16-#23	G: DPx5 (#21) #16-#23	
Thread Trimmer	Yes	No	Yes	No

2-NEEDLE, LOCKSTITCH MACHINES

LH-3568A-7

LH-3568A



LH-3588A-7

LH-3588A

(with large hooks)

(with large hooks)



Semi-dry head, 2-needle, Lockstitch Machine with Organized Split Needle Bar

The sewing machine with organized split needle bars is the only sewing machine in the industry that comes with the semi-dry head. It helps reduce poor-quality products due to oil stains even in the case of product items which have corner stitching sections.

*The semi-dry head sewing machine with organized split needle bars is only available from JUKI.

*A thread tension control mechanism has been developed for each type of sewing machine in order to achieve the best-suited thread tension for its purpose.

*Two selectable new-method oiling mechanisms.



LH-3568A-7

Model name	LH-3568A-7	LH-3568A	LH-3588A-7 (large hooks)	LH-3588A (large hooks)
Application	S: Medium-weight, G: Jeans and heavy-weight		G: Jeans and heavy-weight	
Max. sewing speed	3,000 sti/min			
Max. stitch length	5 mm			
Needle gauge	3.2-25.4 mm (1/8"-1")			
Presser foot	By knee: 13 mm, By hand: 7 mm			
Needle	S : DPx5 (#14) #9-#16 G: DPx5 (#21) #16-#23			
Thread Trimmer	Yes	No	Yes	No



OVERLOCK / SAFETY STITCH MACHINES

MO-6700DA Series

Semi-dry head, High-speed, Overlock / Safety Stitch Machine

Maximum sewing speed is increased to 7,000 sti/min. The needle bar mechanism and upper looper mechanism have been redesigned to require no lubrication. The frequency of stain removal or re-sewing is reduced. The most-advanced dry technologies, such as the special surface treatment applied to the major drive unit and the grease feeding method, contribute to higher durability. The machine does not splash oil after a long-period of use.



Blind hemming - MO-6705DA-0D4-210/L121 (L121: Blind stitch hemming attachment)



Gathering - MO-6714DA-BE6-327/S162 (S162: Swing-type gathering device, manual-lever operated)



Rolling in tape - MO-6745DA-FF4-360/N077 (N077: Clean finish top and bottom)



Model name	MO-6704DA	MO-6714DA	MO-6716DA
Stitch type	1-needle overlock	2-needle overlock	Safety stitching
Max. sewing speed	7,000 sti/min		
Stitch length	0.8-4 mm		1.5-4 mm
Needle gauge	—	2.0, 3.2 mm	3.2, 4.8, 4.8 + 2.0, 3.2 + 2.0 mm
Overedging width	1.6, 3.2, 4.0, 4.8 mm	2.0, 3.2, 4.0, 4.8 mm	
Bottom differential feed ratio	Gathering 1:2 (max. 1:4), Stretching 1:0.7 (max. 1:0.6)		
Needle	DCx27 (excluding some subclass model)		

MO-6700DA-30P

Semi-dry head, High-speed, Overlock / Safety Stitch Machine / Anti-Puckering

The sewing machine is fully equipped with adjusting provisions to effectively prevent puckering of difficult-to-sew materials or new generation materials. The operator is able to produce beautifully finished high-quality seams without conducting difficult adjustments.

The focus on feed and feed timing have been selected to offer optimum conditions for sewing light-weight materials.

The machine comes as standard with a low-pressure presser foot that is exclusively designed for light-weight materials and is able to remarkably handle small curves of the material. The presser foot helps the operator control lighter-weight material smoothly on the machine.

It is equipped with semi-dry technology as it is on MO-6700DA that ensures oil-stain-free sewing.

Model name	MO-6716DA-DE4-30P	MO-6716DA-FF4-30P
Max. sewing speed	7,000 sti/min	
Stitch length	4 mm	
Needle gauge	3.2 mm	4.8 mm
Over Edging width	4 mm	4.8 mm
Bottom differential feed ratio	1:0.7 - 1.2	
Needle	DC x 27 #11	

MO-6800D

Semi-dry-head, High-speed, Overlock / Safety Stitch Machine

This is a semi-dry head overlock machine available in 1.2 or 3 needles. It has been developed to eliminate problems with oil leakages or splashing.

Model name	M0-6804D	M0-6814D	M0-6816D	M0-6843D
Stitch Type	1-needle Overlock	2-needle Overlock	Safety stitching	3-needle safety stitching
Max. Sewing Speed	7,000 sti/min			
Overedging Width	4.0 mm	2.0, 3.0, 4.0 mm		3.0 mm
Needle	DCx27			
Lift of the Presser Foot	7 mm			
Lubrication	Automatic			



MO-6716DA



The feed mechanism feeds double chainstitch looper thread with consistency, even under a low tension. (Safety stitch machine)



MO-6800S

OVERLOCK / SAFETY STITCH MACHINES

MO-6800D/BL Series

Semi-dry-head, High-speed, Overlock Machine, Full Automatic Back Latch

MO-6800S/BL Series

High-speed, Overlock Machine, Full Automatic Back Latch

This machine comes with a full automatic back latch which when the sewing process is finished, the chain is auto-pulled back immediately, and with a 4-thread overlock stitch the stitch is perfectly tight without chain losing. This advanced overlock is easy to use and promises great quality garment. The back latch can be as short as 3cm, and the tension is stable without human factors.



MO-6800D/BL

Model name	MO-6800/BL Series
Motor / Control Box	Direct-drive, 400W, Max. 7000 sti/min, 200~240V
Touch Panel	Maximum 26 sewing programs saving, Maximum 20 sections setting per program. 9 types of sewing mode.
Edge Sensor	Setting the stitch number for each function
Suction Trimmer	Provided as standard
Vacuum Waste Set	Provided as standard
Auto Thread Control	Provided as standard
Auto Presser foot lifter	Provided as standard

Model No.	MO-6804S-0E4-30H/BL	MO-6814S-BE6-30H/BL	MO-6814D-BE6-30H/BL
Number of needles	1	2	2
Number of threads	3	4	4
Needle gauge	-	2	2
Overedging width	4.0	3.6	3.0
Number of feed dog rows	2	3	3
Stitch length (mm)	3.8	3.8	3.8
Bottom differential feed ratio	1:0.7~1:2	1:0.7~1:2	1:0.7~1:2
Presser lifting amount (mm)	6.0	5.5	5.5
Needle system	DCx27#11	DCx27#11	DCx27#11
Max sewing speed (sti/min)	7.000	7.000	7.000

MO-6800S Series

High-speed, Overlock / Safety Stitch Machine

The MO-6800S Series responds to various kinds of sewing materials and processes, producing delicate and beautiful soft-to-the-touch seams while further reducing operating noise as well as increasing durability. This advanced overlock / safety stitch machine is easier to use and promises superior cost-effectiveness.

Model name	MO-6804S	MO-6814S	MO-6816S
Stitch type	1-needle overlock	2-needle overlock	Safety stitching
Max. sewing speed	7.000 sti/min		
Stitch length	0.6~3.8 (4.5) mm		
Needle gauge	-	2.0 mm	3.0, 5.0 mm
Overedging width	1.5, 4.0 mm	3.0, 4.0 mm	4.0, 5.0, 6.0 mm
Differential feed ratio	For gathering 1:2 (Max. 1:4), For stretching 1:0.7 (Max. 1:0.6)		
Needle	DCx27 (excluding some subclass model)		



MO-6816S

MO-6900S Series

MO-6900R Series

(variable top-feed)



Super-high-speed, Overlock / Safety Stitch Machine

Since the machine comes with a needle-thread take-up mechanism as well as a looper thread take-up mechanism, to offer upgraded responsiveness from light- to heavy-weight materials with a lower applied tension, it achieves well-tensed soft-feeling seams that flexibly correspond to the elasticity of the material at the maximum sewing speed of 8.000 to 8.500 sti/min.



MO-6914S

Model name	MO-6904S	MO-6914S	MO-6916S	MO-6904R	MO-6914R	MO-6916R
Stitch type	1-needle overlock	2-needle overlock	Safety stitching	1-needle overlock	2-needle overlock	Safety stitching
Max. sewing speed	8.500 sti/min	8.000 sti/min		7.000 sti/min, 6.000 sti/min		
Stitch length	0.8~4 mm	1.5~4 mm	0.8~4 mm	1.5~4 mm		
Needle gauge	-	2.0, 2.4, 3.2 mm	2.0, 3.2, 4.0, 4.8, 4.8+2.0 mm	-	2.0 mm	3.2, 4.8, 4.8+2.0 mm
Overedging width	1.6, 3.2, 4.0, 4.8 mm	3.2, 4.0, 4.8 mm	3.2, 4.0, 4.8, 6.4 mm	3.2, 4.0, 4.8, 6.4 mm	3.2, 4.0 mm	3.2, 4.0, 4.8, 6.4 mm
Differential feed ratio	Gathering 1:2 (max. 1:4), Stretching 1:0.7 (max. 1:0.6)					
Needle	DCx27 (excluding some subclass model)					



MO-6900J Series

(variable top-feed)



MO-6900G Series

(bottom-feed)

Overlock / Safety Stitch Machine for Extra Heavy-weight Materials

The machine incorporates a mechanism and parts that are optimum for the sewing of extra heavy-weight materials, such as an extra high-lift type upper looper, tractor foot and coarse type feed dog. It demonstrates an excellent performance ability in the sewing of various kinds of heavy-weight materials such as jeans, raised fabric materials, mats and carpets.



MO-6916J

Model name	MO-6904J	MO-6914J	MO-6916J	MO-6904G	MO-6914G	MO-6916G
Stitch type	1-needle overlock	2-needle overlock	Safety stitching	1-needle overlock	2-needle overlock	Safety stitching
Max. sewing speed	6.000 sti/min					
Stitch length	2.5~5 mm	2.5~4 mm	2.5~5 mm		2.5~4 mm	2.5~5 mm
Needle gauge	—	2.6 mm	4.8 mm	—	2.6 mm	4.8 mm
Overedging width	4.8 mm	6.4 mm	4.8, 6.4 mm	4.8, 10.0, 18.0 mm	6.4 mm	4.8, 6.4 mm
Differential feed ratio	Gathering 1:1.75 (max. 1:3.8) Stretching 1:0.7 (max. 1:0.6)	Gathering 1:2 (max. 1:3.8) Stretching 1:0.8 (max. 1:0.6)	Gathering 1:1.75 (max. 1:3.8) Stretching 1:0.7 (max. 1:0.6)	Gathering 1:1.75 (max. 1:3.8) Stretching 1:0.7 (max. 1:0.6)	Gathering 1:2 (max. 1:3.8) Stretching 1:0.8 (max. 1:0.6)	Gathering 1:1.75 (max. 1:3.8) Stretching 1:0.7 (max. 1:0.6)
Needle	DOx5 (excluding some subclass model)					

MO-6900C Series

Super-high-speed, Cylinder-bed, Overlock Machine

The machine provided with a small-in-diameter cylinder bed, is capable of run stitching or blind-hemming tubular materials, such as sleeve cuffs, with ease.

Model name	MO-6904C	MO-6914C
Stitch type	1-needle overlock	2-needle overlock
Max. sewing speed	8.000 sti/min	
Stitch length	0.8~3.5mm	
Needle gauge	—	2.0 mm
Overedging width	3.2, 4.0, 4.8 mm	3.2, 4.0 mm
Bottom differential feed ratio	Gathering 1:2.3 (max. 1:4.5), Stretching 1:0.8	
Needle	DCx27	



MO-6914C

MO-6914C-BD6-307/X81028

(variable top-feed type)

High-speed, Cylinder-bed, 2-needle Overlock Machine

The machine comes with the top feed dog that moves along an ideal locus. The feed dog securely catches the material and allows the multi-layer portion of a material to be fed under it with consistency. In addition it helps finish uniform seams while preventing the presser foot from jumping and smoothly feeds the material without fail.

Compact-shape of the cylinder effectively prevents the material from being fed unevenly and from twisting in various kinds of sewing of tubular materials e.g., joining sleeve cuffs of which diameter is small and blind hemming long materials.



MO-6914C-BD6-307/X81028

Model name	MO-6914C-BD6-307/X81028
Stitch type	2-needle overlock
Max. sewing speed	7.000 sti/min (longitudinal stroke of top feed dog is 6 mm or less) 6.000 sti/min (longitudinal stroke of top feed dog is 6~8.5 mm)
Stitch length	0.8~3.5 mm
Needle gauge	2.0 mm
Overedging width	3.2 mm
Bottom differential feed ratio	For gathering 1:2.3, For stretching 1:0.8
Needle	DCx27



Overlock and Safety Stich Devices

Model	Item Name	Description	Item Number
	T053	Pneumatic type flat cutter	70000081
	T054	Pneumatic type side cutter	70000082
	MC904/MC-4	Chain-off thread suction device for Clutchmotor user	70000083
	MC907/MC-4	Chain-off thread suction device for Servomotor user	70000102
	MC905/AK-52	Chain-off thread suction device with auto-lifter for Clutchmotor user	70000084
	MC908/AK-52	Chain-off thread suction device with auto-lifter for Servomotor user	70000103
	MC906/MC-8	Cloth chips & chain-off thread suction device for Clutchmotor user	70000085
	MC909/MC-8	Cloth chips & chain-off thread suction device for Servomotor user	70000104
	MC910/MC-9	Cloth chips & chain-off thread suction device with auto lifter for Clutchmotor user	70000106
	MC911/MC-9	Cloth chips & chain-off thread suction device with auto lifter for Servomotor user	70000107
	S206	Swing-type gathering device (interlocked with pedal/for overlock machine)	70000089
	S207	Swing-type gathering device (interlocked with pedal/for overlock machine) DF6	70000090
	Z892	Swing-type gathering device (interlocked with pedal/for overlock machine) FF6	70000091
MO-6700 & MO-6800	Z892	Backlatching function for single needle (0E6) user	70000086
	Z893	Backlatching function for double needle (BD4) user	70000087
	Z894	Backlatching function for double needle (BE4) user	70000088
	Z065	Angle knife for overlock	70000092
	Z067	Angle knife for safety stitch machine	70000093
	N079	Fold double & attaching reinforcement tape binder for safety stitch machine (DF6)	70000094
	N080	Fold double & attaching reinforcement tape binder for safety stitch machine (FF6)	70000095
	G35	Pressure foot for attaching zipper for single needle overlock machine	70000097
	R040	Tape stand for spin tape	70000098
	Q143	Tape guide for G44	40159863
	R037	Tape Stand	70000100
	H253	Cloth edge guide ruler for overlock machine	40159861
	H254	Cloth edge guide ruler for safety stitch machine	40159862
MO-6845S	N075	Clean finish top and bottom, Reinforcement tape attachment binder for MO-6845S	70000105
	MC4	Pneumatic suction of chain-off, pedal activate	83012401
	MC5	Pneumatic suction of chain-off	83012419
	MC8	Pneumatic suction of chain-off and chip	83012443
MO-6900 Series	MC9	Pneumatic suction of chain-off and chip, footlifter for T039/041/042	83012443
	MC24	Pneumatic chain-off thread & cloth chips for T040	MC24
	MC38	Pneumatic suction of chain-off and chip for T043	29163706
	MC39	Pneumatic suction of chain-off and chip, footlifter for T043	29163706
MO-6900S		Electromagnetic one-touch chopper MO-6900S	40044156
MO-6900R		Electromagnetic one-touch chopper MO-6900R	40044158
MO-6900G	T039	Electromagnetic one-touch chopper MO-6900G	40044160
MO-6900J		Electromagnetic one-touch chopper MO-6900J	40044162
MO-6900S		Automatic chain-off trimmer MO-6900S semi-sunken	40043897
MO-6900S		Automatic chain-off trimmer MO-6900S full-sunken	40043899
MO-6900R		Automatic chain-off trimmer MO-6900R semi-sunken	40043901
MO-6900R		Automatic chain-off trimmer MO-6900R full-sunken	40043903
MO-6900G	T040	Automatic chain-off trimmer MO-6900G semi-sunken	40043905
MO-6900G		Automatic chain-off trimmer MO-6900G full-sunken	40043907
MO-6900J		Automatic chain-off trimmer MO-6900J semi-sunken	40043909
MO-6900J		Automatic chain-off trimmer MO-6900J full-sunken	40043911
MO-6900S	T041S	Pneumatic flat cutter MO-6900S	40075885
MO-6900R		Pneumatic flat cutter MO-6900R	40060703
MO-6900S	T042S	Pneumatic side cutter MO-6900S	40045967
MO-6900S	T043	Pneumatic side cutter MO-6900C	MAT043000A0
MO-6900R	T045	Pneumatic side cutter MO-6900R	MAT045000A0
MO-6900R	T048	Pneumatic flat cutter MO-6904G, MO-6914G	MAT048010A0
MO-6904G, MO-6914G		Pneumatic flat cutter MO-6904J, MO-6914J	MAT048010B0
MO-6916G	T050	Pneumatic flat cutter MO-6916G	MAT050010A0
MO-6916J		Pneumatic flat cutter MO-6916J	MAT050010B0
		Curly Preventing Binder (MO) Air Type	70005429

MO-6800 Consumable Kit

MO-6800	Description	Quantity	
Kit P/N	40160620	KIT_PARTS	1 set
Construction Part Numbers	70000405	LOWER LOOPER	2
	70000505	E SCREW	2
	70000229	UPPER KNIFE	10
	70000510	E SCREW	10
	70000399	LOWER KNIFE	20
	70000517	E SCREW	20





ZIGZAG STITCHING MACHINES

LZ-2290C-7

LZ-2290C



Semi-Dry head, Digital Zigzag Stitching Sewing System

The LZ-2290C series has two specifications of full digital and digital. In the full digital specification, Vertical, Horizontal feeding mechanism are motorized to allow simplified parameter adjustments via the control panel. Feed timing which traditionally requires long duration of adjustment can now be simply changed via the control panel. System also allows changes from (Soft ⇄ Standard ⇄ Hard) settings based on the process suitability. Also, fabric slip prevention feeding locus can be changed to further increase range of workable material.



LZ-2290C



Hook timing adjustment mode



Model name	LZ-2290CF-7	LZ-2290CS-7	LZ-2290CS
Type	Full Digital Type	Digital Type	
Max. sewing speed	5,000 sti/min		
Max. zigzag width	8 mm		
Max. stitch length	5 mm		
Number of patterns for standard stitching	11 types / 20 patterns		
Custom pattern memory capacity	200 patterns		
Needle	DPx5(#10), 438(Nm75)		

ZIGZAG STITCHING MACHINES

LZ-2280A

High-speed, 1-needle, Lockstitch, Zigzag Stitching Machine (standard zigzag / standard wider zigzag)

The standard zigzag stitching machine which creates softly finished seams. The needle rocking mechanism is provided with a triangular cam which helps produce beautiful seams with consistency.

Model name	LZ-2280AA	LZ-2280AB
Stitch system	Standard zigzag	Standard wider zigzag
Stitch pattern		
Max. sewing speed	5.000 sti/min	
Max. zigzag width	5 mm	8 mm
Max. stitch length	2.5 mm	5 mm
Needle	134 SUK (Nm70)	



LZ-2280A

LZ-2284A-7

LZ-2284A



High-speed, 1-needle, Lockstitch, Zigzag Stitching Machine (with standard / 3-step zigzag stitching pattern changeover function)

Designed to handle both standard and 3-step zigzag stitching, the machine offers increased availability. The sewing machine starts up swiftly and promises increased stop accuracy, thereby demonstrating improved responsiveness.

Model name	LZ-2284A-7, 2284A
Stitch system	Standard / 3-step zigzag
Stitch pattern	
Max. sewing speed	5.000 sti/min
Max. zigzag width	10 mm (standard) / 10 mm (3-step)
Max. stitch length	2.5 mm
Needle	134 SUK (Nm70)
Thread Trimmer	Yes / No



LZ-2284A-7



Please scan here to see a video

LZ-2287A

High-speed, 1-needle, Lockstitch, Zigzag Stitching Machine (with 3-step zigzag / scallop stitching pattern changeover function)

Designed to handle both 3-step zigzag and scallop stitching, the machine offers increased availability.

Model name	LZ-2287A
Stitch system	3-step zigzag / scallop
Stitch pattern	
Max. sewing speed	5.000 sti/min
Max. zigzag width	10 mm
Max. stitch length	2.5 mm
Needle	134 SUK (Nm70)



LZ-2287A

LZ-2284C-7

High-speed, Cylinder-bed, 1-needle, Lockstitch, Zigzag Stitching Machine (with standard / 3-step zigzag stitching pattern changeover function)

The cylinder bed zigzag stitch machine is best suited to the circular stitching processes of tubular products such as girdles, shorts and swimwear.

Model name	LZ-2284C-7
Stitch system	Standard / 3-step zigzag
Stitch pattern	
Max. sewing speed	5.000 sti/min Standard zigzag: zigzag width of 5 mm or less 3-step zigzag: zigzag width set to 8 mm or less
Max. zigzag width	Standard zigzag: 8 mm, 3-step zigzag: 10 mm
Max. stitch length	Standard zigzag: 2.5 mm, 3-step zigzag: 2 mm
Peripheral dimension of the cylinder section	322 mm
Needle	438 (#75), DPx5 (#10)
Thread Trimmer	Yes / No



LZ-2284C-7

LZ-271

(for embroidering only)

LZ-391N

1-needle, Lockstitch, Zigzag Stitching Machine and Embroidering Sewing Machine

The machine is capable of embroidering names and marks on sewing products, as well as zigzag stitching, by simply changing the throat plate. When using this machine for zigzag stitching, the zigzag width and stitch length can be changed so that many different types of zigzag stitch can be sewn.

Model name	LZ-271	LZ-391N
Max. sewing speed	2.000 sti/min (with zigzag width is set to 10 mm) 1.700 sti/min (with zigzag width is set to 12 mm)	
Needle bar stroke	33.4 mm	
Zigzag width	0~12 mm	
Stitch length	—	Max. 5 mm
Needle	DBx1B (#11) #9~#18	DBx1B (#14) #9~#16



LZ-391N

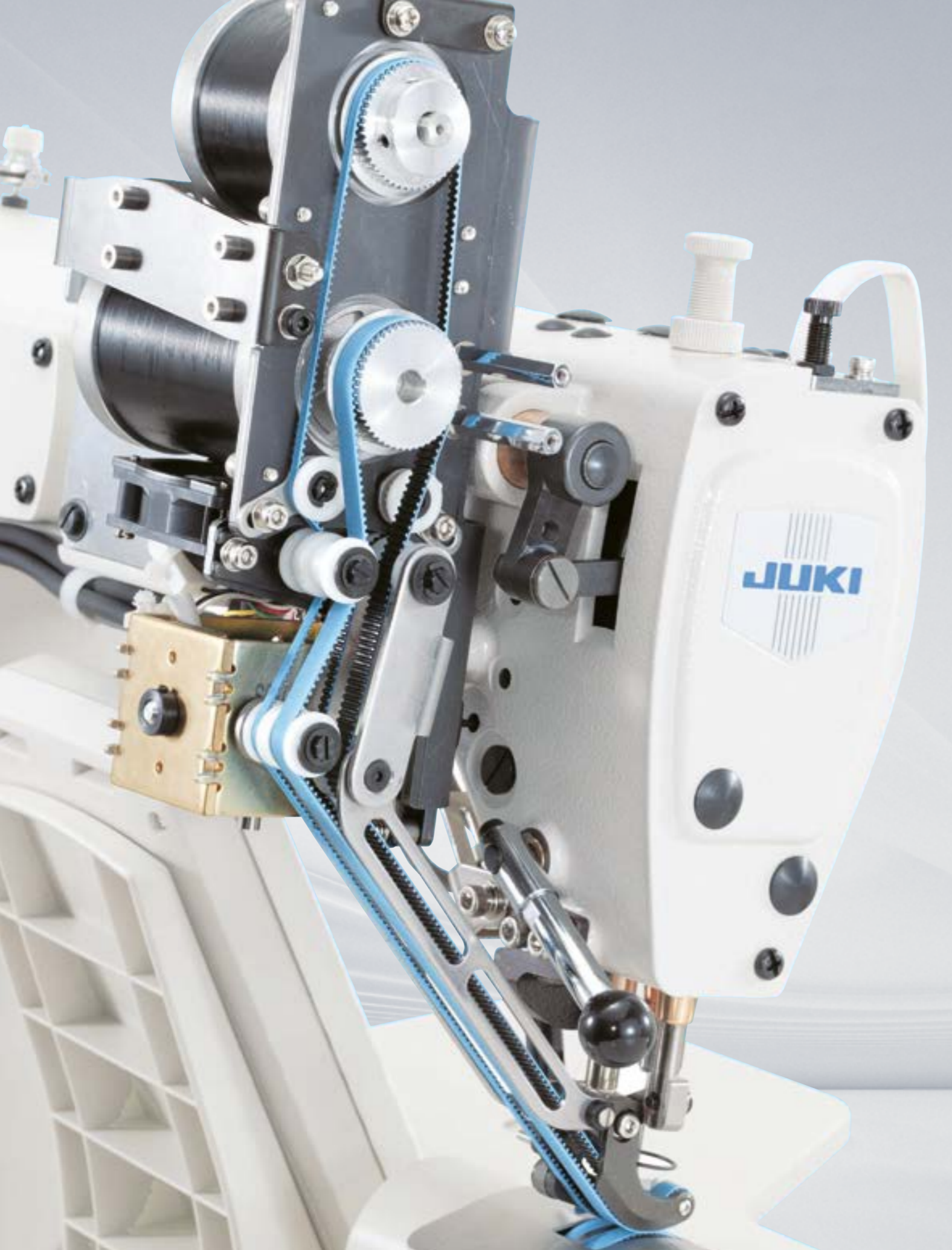

POST BED SEWING MACHINES

DP-2100

Computer-controlled, Dry-head, Lockstitch Sleeve Setting Machine with Multi-programming Device

The machine is the culmination of JUKI's leading edge technologies to enable a sleeve setting process, which is the most difficult of all sewing processes, thereby more easily achieving upgraded seam quality. The machine comes with a newly developed belt feed mechanism that offers excellent responsiveness to materials and ease of their handling.

Model name	DP-2100
Max. sewing speed	3.500 sti/min (feed pitch 1.5~4.0 mm)
Stitch length (both top and bottom)	1.5~6 mm
Amount of the alternating vertical movement of the presser foot and walking foot	Max. 3.5 mm
Number of programs that can be input	99 programs
Number of steps that can be input (for one program)	30 steps
Needle	DPx17#10-#14



DP-2100



New type belt feed mechanism



Alternating vertical movement mechanism



Active tension mechanism

LT-591

1-needle, Lockstitch, Post-bed type Basting Machine

This model is a specially developed machine to increase the sewing efficiency of basting process.

Model name	LT-591
Max. sewing speed	600 sti/min
Max. stitch length	Free
Needle	TVx7 (#14)



LT-591

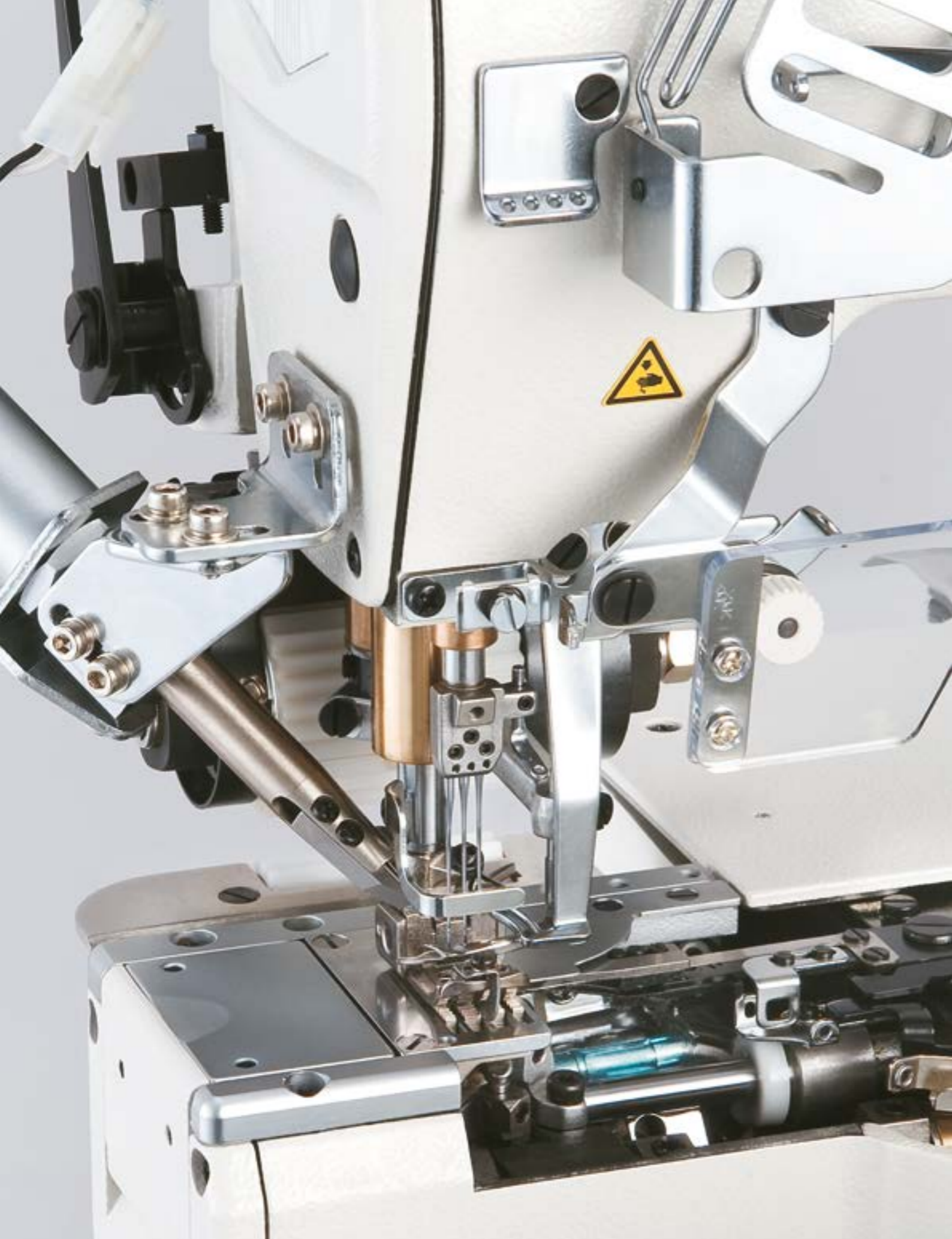

COVERSTITCH MACHINES

MF-7500-U11

MF-7500-U11/UT

MF-7500D-U11

(semi-dry head)



MF-7500D-U11/UT

(semi-dry head)



High-speed, Flat-bed, Top and Bottom Coverstitch Machine (universal type)

The machine can be used for the hemming process of the sleeves and bottoms of T-shirts and for the covering process for sportswear and knitwear.

The front cover is trimmed to allow operators to bring their hands closer near the needle entry area, thereby increasing work efficiency in the covering process, etc.

The MF-7500/X83068 is available in both high speed and dry head types but without thread trimming.

Model name	MF-7500/U11	MF-7500D/U11
Max. sewing speed	6.500 sti/min	5.000 sti/min
Needle gauge	3.2, 4.0, 4.8, 5.6, 6.4 mm	5.6, 6.0, 6.4 mm
Stitch length	1.2~3.6 mm	
Needle	UY128GAS (#10S) #9S~#12S	

MF-7500-C11

MF-7500D-C11

(semi-dry head)

High-speed, Flat-bed, Top and Bottom Coverstitch Machine (collarettte attaching)

This model is best suited for attaching collarettes on underwear, briefs and knitwear. Ease of use is further improved by using the electromagnetic type tape cutter (TC16).



Model name	MF-7500-C11	MF-7500D-C11
Max. sewing speed	6.500 sti/min	5.000 sti/min
Needle gauge	3.2, 4.0, 4.8, 5.6, 6.4 mm	4.0, 5.6, 6.4 mm
Stitch length	1.2~3.6 mm	
Needle	UY128GAS (#10S) #9S~#12S	



MF-7523-U11/UT



T-shirts

Knitwear

Swimwear

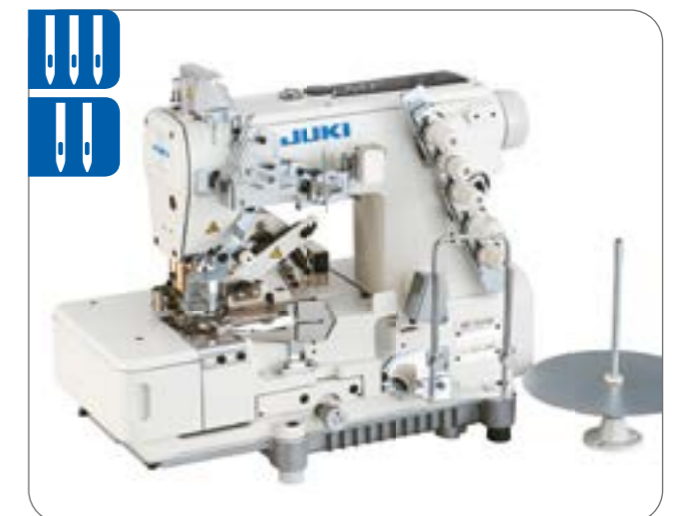

MF-7523D-C11

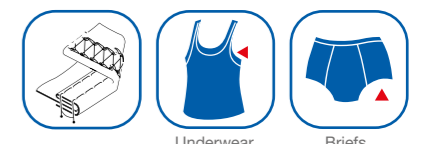

Underwear

Briefs

COVERSTITCH MACHINES

MF-7500-E11

MF-7500D-E11

(semi-dry head)

High-speed, Flat-bed, Top and Bottom Coverstitch Machine (elastic lace attaching with right hand fabric trimmer)

The machine is intended for the elastic lace attaching of shorts, lingerie and foundations. The right hand fabric trimmer cuts the multi-layered section of joined seams without fail to achieve uniformly and beautifully finished seams, with the seams and material-edge aligned.

Model name	MF-7500-E11	MF-7500D-E11
Max. sewing speed	6.500 sti/min	5.000 sti/min
Needle gauge	3.2, 4.0, 5.6, 6.4mm	4.0, 5.6, 6.4 mm
Stitch length	0.9-3.6 mm	
Needle	UY128GAS (#10S) #9S-#12S	

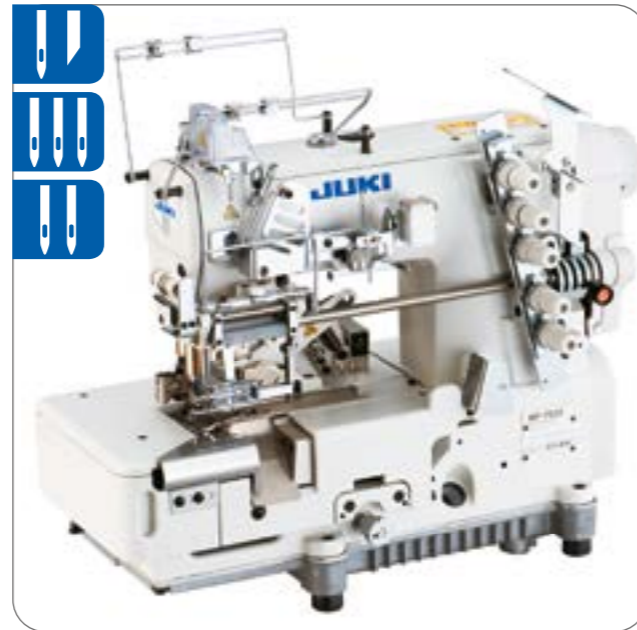

MF-7523-U11-E11



Ladies' inner wear Shorts

MF-7900-U11

MF-7900-U11/UT



MF-7900D-U11

MF-7900D-U11/UT

(semi-dry head)



High-speed, Cylinder-bed, Top and Bottom Coverstitch Machine (universal type)

The machine can be used for the hemming process of the sleeves and bottoms of T-shirts and for the covering process for sportswear and knitwear.

The front cover is trimmed to allow operators to bring their hands closer near the needle entry area, thereby increasing work efficiency in the covering process, etc.

Model name	MF-7900-U11	MF-7900D-U11
Max. sewing speed	6.500 sti/min	5.000 sti/min
Needle gauge	3.2, 4.0, 4.8, 5.6, 6.4 mm	4.0, 5.6, 6.4 mm
Stitch length	0.9-3.6 mm	
Needle	UY128GAS (#10S) #9S-#12S	



MF-7923-H11-U11/UT



T-shirts Polo shirts Knitwear Swimwear

MF-7900-H11

MF-7900-H11/UT



High-speed, Cylinder-bed, Top and Bottom Coverstitch Machine (hemming)

The machine is intended for the hemming of knit shirts and T-shirts. This model is best suited to elastic-band welting for swimwear, briefs, etc. It welts the elastic band which has been overlapped on the garment body.

Model name	MF-7900-H11/PL
Max. sewing speed	5.000 sti/min
Needle gauge	5.6, 6.4 mm
Stitch length	0.9-3.6 mm
Needle	UY128GAS (#10S) #9S-#12S

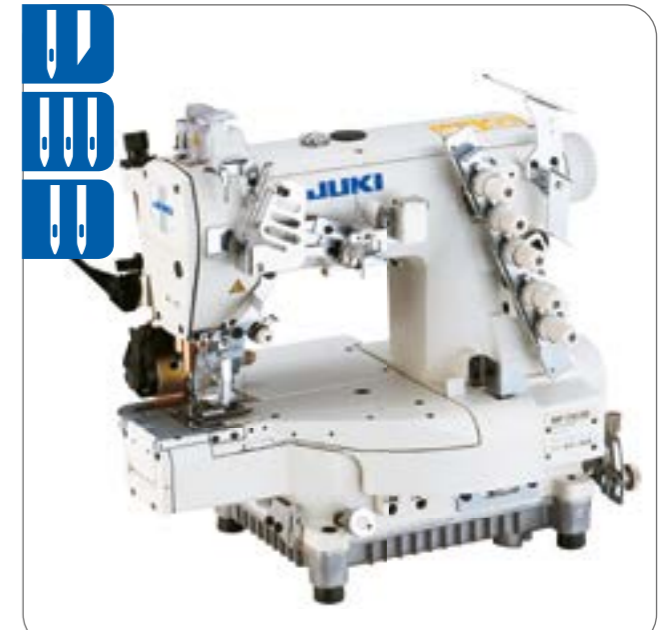

MF-7523-U11-E11



T-shirts Polo shirts Swimwear Briefs

MF-7900-H22,23

MF-7900-H22,23/UT



MF-7900D-H22,23

(semi-dry head)

MF-7900D-H22,23/UT

(semi-dry head)



High-speed, Cylinder-bed, Top and Bottom Coverstitch Machine (hemming with left hand fabric trimmer)

This model is best suited to hemming processes for sleeves and the bottoms of T-shirts, Polo shirts, etc. It comes with a left hand fabric trimmer for trimming fabric in parallel, at all times, to the seam with consistency. The upper knife stroke can be adjusted with ease.

Model name	MF-7900-H22,23/UT	MF-7900D-H22,23
Max. sewing speed	6.000 sti/min	5.000 sti/min
Needle gauge	4.0, 4.8, 5.6, 6.4 mm	4.8, 5.6, 6.4 mm
Stitch length	0.9-3.6 mm	
Needle	UY128GAS (#10S) #9S-#12S	

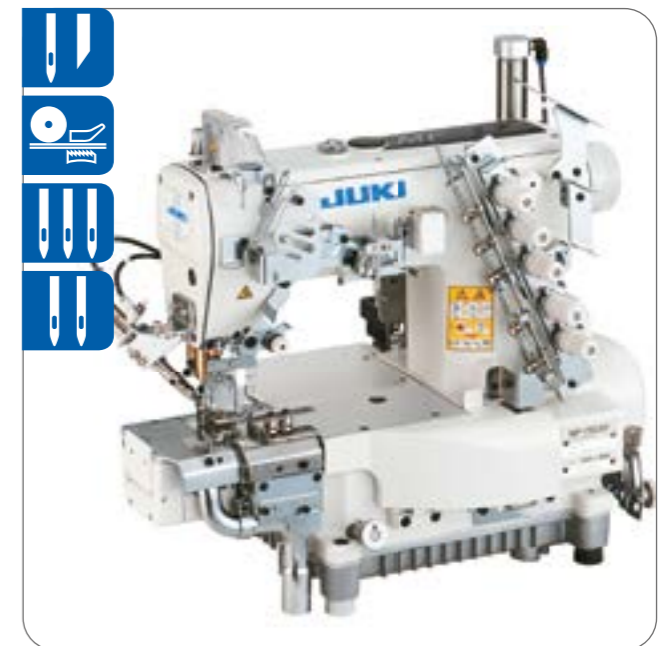

MF-7923D-H23/UT



T-shirts Polo shirts

COVERSTITCH MACHINES

MF-7900D-H24/UT MF-7900D-H25/UT

(with sliding presser foot)

Semi-dry head, Cylinder-bed, Top & Bottom Coverstitch Machine (hemming with left hand fabric trimmer, for extra light-weight materials)

The machine is best-suited for the hemming of stretchy new material such as T-shirts, underwear and sportswear, etc. The machine produces seams with no semi-cylindrical swells by performing sewing while making the feeding lengths of the right and left needle threads equal. The sliding presser foot prevents the material hem from twisting during sewing and further eliminates oblique-feeding of the material in terms of its texture.

Model name	MF-7900D-H24	MF-7900D-H25
Max. sewing speed	5.000 sti/min	
Needle gauge	3.2, 4.0, 5.6 and 6.4 mm	
Stitch length	0.9~3.6 mm	
Needle	UY128GAS (#10S) #9-#12S	

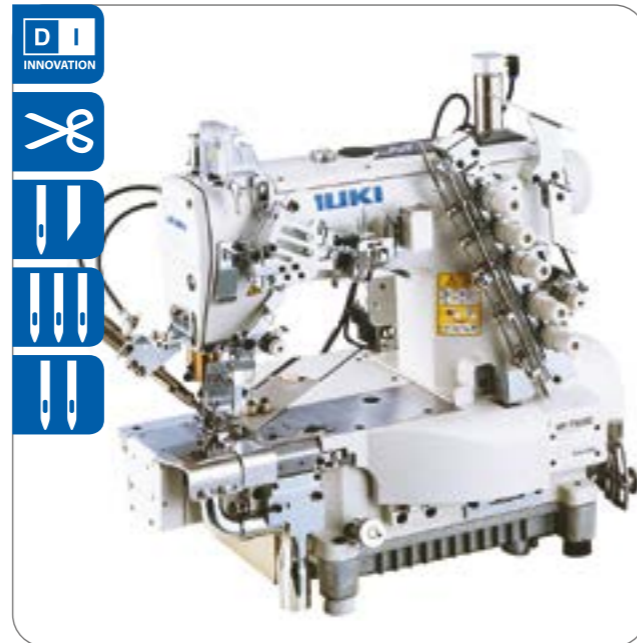

MF-7923D-H24/UT

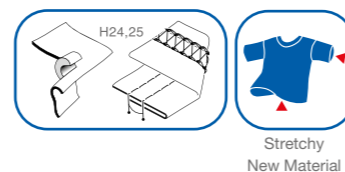

MF-7900DR-H24 Series

Semi-dry head, Cylinder-bed, Bottom Coverstitch Machine with digital type top feed. For hemming.

The machine is provided with the digital type top feed mechanism. This mechanism prevents problems, such as twist of fabric, uneven material feed, skew of grain and stitch gathering on multi-layered sections of material, which are likely to occur when sewing elastic materials, thereby achieving stable seam quality.

Model Name	MF-7900DR-H
Max. sewing speed	5.000 sti/min
Stitch type	bottom covering stitch
Feed mechanism	Digital type top feed
Stitch length	0.9 mm~3.6 mm
Needle	UY128GAS #9S~12S(#10S)

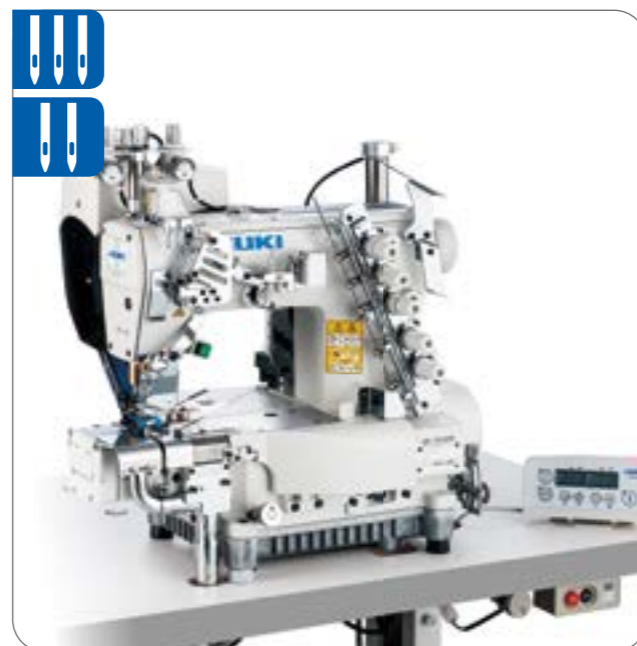

MF-7913DR-H24-E64



Please scan here to see a video

MF-7900-E11 MF-7900-E11/UT



MF-7900D-E11 MF-7900D-E11/UT

(semi-dry head)

(semi-dry head)



High-speed, Cylinder-bed, Top and Bottom Coverstitch Machine (elastic band attaching with right hand fabric trimmer)

This model is best suited to endless flat elastic band sewing processes for briefs, boxer briefs, etc. The right hand fabric trimmer trims the fabric, even at a multi-layered joined part, to produce a beautiful finish with the seam and fabric edge aligned with consistency. The right hand fabric trimmer mechanism is a unit-structure to permit easy installation / removal. This contributes to easier adjustments, such as looper aligning.

Model name	MF-7900-E11/PL	MF-7900D-E11
Lubrication	Automatic (frame: no lubrication)	
Max. sewing speed	5.000 sti/min	
Needle gauge	4.0, 5.6, 6.4 mm	5.6 mm
Stitch length	0.9~3.6 mm	
Needle	UY128GAS (#10S) #9S-#12S	



MF-7913D-E11

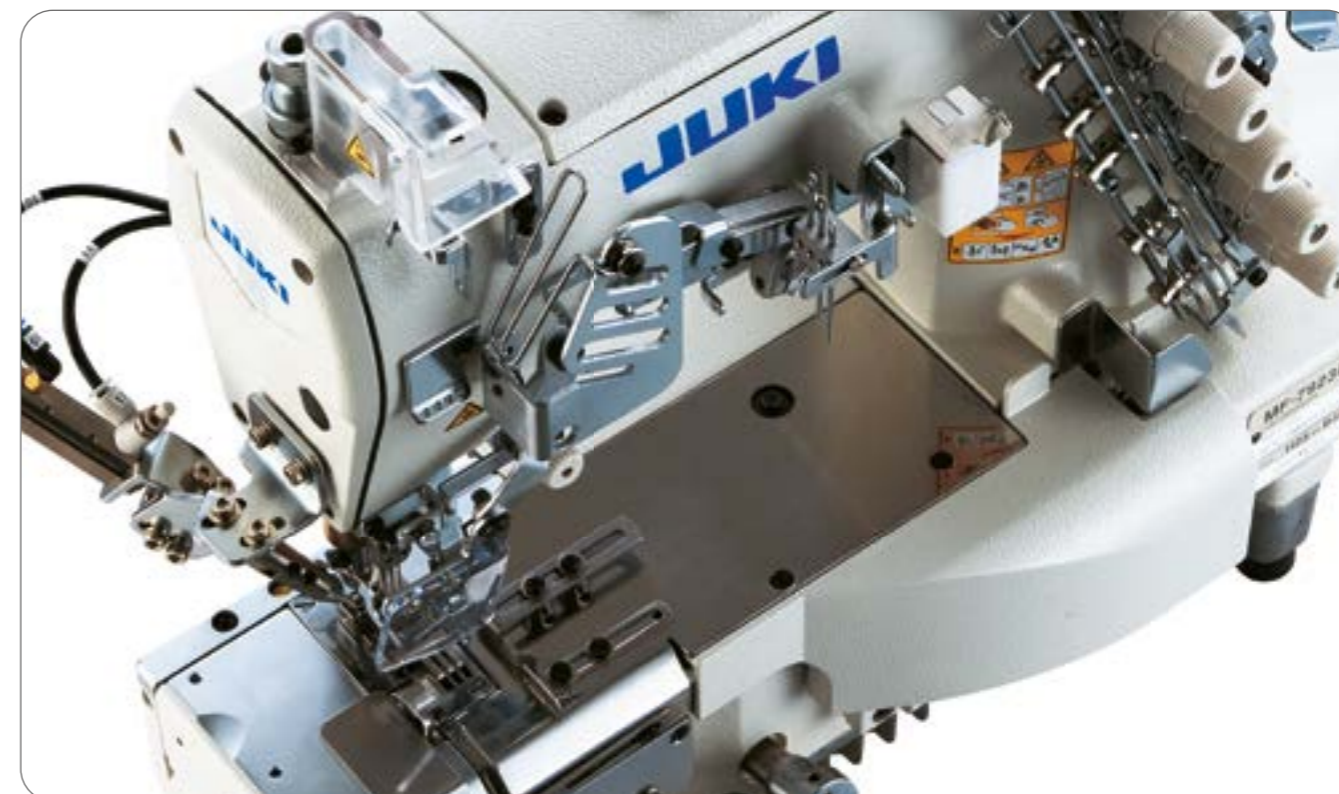
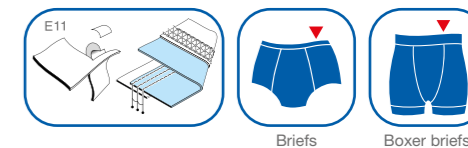

COVERSTITCH MACHINES

MF-7900-E22

(with manual binder)

MF-7900-E22/UT

(with manual binder)



MF-7900-E23

(with air binder)

MF-7900-E23/UT

(with air binder)



High-speed, Cylinder-bed, Top and Bottom Coverstitch Machine (endless spandex elastic band attaching)

The machine is used for spandex elastic band sewing processes for briefs. The machine produces soft seams, making it best-suited for band attaching processes where seams are required to have sufficient elasticity.

Model name	MF-7900-E22,23/PL
Lubrication	Automatic (frame: no lubrication)
Max. sewing speed	5,000 sti/min
Needle gauge	5.6, 6.4 mm
Stitch length	0.9-3.6 mm
Needle	UY128GAS (#10S) #9S-#12S



MF-7923-E22



Briefs

MF-7200D-U10

(universal type)

MF-7200D-U10/UT

MF-7200D-K10

(covering)

MF-7200D-K10/UT

Semi-dry-head, Small-cylinder-bed, Top and Bottom Coverstitch Machine

The small cylinder-bed and semi-dry head features have been achieved while placing priority on ease of use.

Outer circumference of the cylinder section is 176 mm! The cylinder has the industry's smallest diameter.

The outer circumference of the cylinder section has been reduced to 176 mm. This allows the sewing machine to easily sew conventionally hard-to-sew small-in-diameter tubular parts such as the sleeve cuffs of sportswear and ladies' cut-and-sewn wear and the necklines of children's wear.

Model name	MF-7200D
Lubrication	Automatic (frame: no lubrication)
Max. sewing speed	4,000 sti/min
Needle gauge	5.6, 6.4 mm
Stitch length	Max. 4.2 mm
Needle	UY128GAS (#10S) #9S-#12S



MF-7223D-U10



UT51

Electromagnetic needle thread/ looper thread trimming device / Auto-lifter

It is an electromagnetic needle thread / looper thread trimming device / Auto-lifter. The machine does not need an air compressor to achieve easy layout changing.



Electromagnetic needle thread / looper thread trimming device



Presser lifter drive mechanism magnet
Thread trimmer drive mechanism magnet

UT52

Electromagnetic needle thread / looper thread trimming device / Auto-lifter

It is an electromagnetic needle thread / looper thread trimming device / Auto-lifter with cloth puller.



Electromagnetic needle thread / looper thread trimming device



Presser lifter drive mechanism magnet
Thread trimmer drive mechanism magnet

UT53

Electromagnetic type bottom thread trimming device + Electromagnetic type wiper / Auto-lifter

This is an electromagnetic type bottom thread trimming device / auto-lifter. It is used for processes which do not need top covering.

UT55

Pneumatic type bottom thread trimming device + Electromagnetic type wiper / Auto-lifter

This is a pneumatic type bottom thread trimming device / auto-lifter. It is used for processes which do not need top covering.

UT57

Pneumatic type needle thread / looper thread trimming device / Auto-lifter

It is a pneumatic type needle thread / looper thread trimming device / Auto-lifter. Since the automatic lift of the presser foot and automatic thread trimming can be activated by lightly depressing the pedal, work efficiency is dramatically increased. The air blow type wiper is supplied with the sewing machine as an accessory.

UT59

Pneumatic type top and bottom thread trimming device with thread-fray-prevention function

It is the state-of-the-art function to make the thread-fray-prevention at the end of sewing more reliable.

UT59 cannot be attached to the machine as a device.
Please order with the machine head.



Pneumatic type needle thread / looper thread trimming device.



Presser lifter drive mechanism air cylinder.
Thread trimmer drive mechanism air cylinder.



By making the pitches shorter at the end the thread won't be easily loosened.

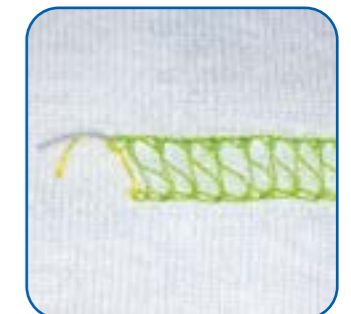

By making a knot at the end of sewing the thread won't be frayed.

COVERSTITCH MACHINES

SS11

Short stitch device: Part No.70004376

This is a device for preventing the thread from coming undone at the end of sewing. The device is able to sew condensation stitches by the number specified as desired. It prevents the needle thread from being poorly tensed, which is likely to occur in cases where the amount of condensation is reduced.



PL12

Cloth puller: Gear type

This is a gear type cloth puller. It helps feed difficult-to-feed materials to assist smooth sewing.

(Example: Attaching flat elastic bands)



Pneumatic type needle thread / looper thread trimming device

PL13

Cloth puller: Flat type

This is a flat type cloth puller. It helps feed soft material which requires a higher feeding force to assist sewing.

(Example: Hemming)



Presser lifter drive mechanism air cylinder
Thread trimmer drive mechanism air cylinder

Item Name	Description	Item Number
MC37	Pneumatic suction device electromagnetic valve	40024640
MC40	Pneumatic suction device mechanical valve	40024641
TC16A	Electromagnetic tape cutter for C11	70002754
TC16A	Electromagnetic tape cutter for E11	70002757
TC16C	Electromagnetic tape cutter for C11 with servo motor	70002756
TC16C	Electromagnetic tape cutter for E11 with servo motor	70002759
TC13A	Tape Cutter with controller for C10 type	40028805
TC13A	Tape Cutter with controller for C10 type	40028805
TC13A	Tape Cutter with controller for E10 type	40028808
TC13C	Tape Cutter for Servo Motor for C10 type	40028807
TC13C	Tape Cutter for Servo Motor for E10 type	40028810

MF-3620

4-needle, Feed-off-the-arm, Flatseamers, Top and Bottom Coverstitch Machine

A direct-drive servomotor has been introduced as an addition to the MF Series of JUKI sewing machines. The enhanced responsiveness of the MF-3620 gives the operator complete control over the material when sewing curved sections. The thread take-up mechanism arranged on the outside of the arm prevents the entry of oil splashes and dust. The MF-3620 is also configured with JUKI's unique oil-thrower mechanism to protect the looper section from oil infiltration.

Model name	MF-3620-B (direct-drive type)	MF-3620 (belt-drive type)
Application	Light- to heavy weight (knit)	
Max. sewing speed	4.200 sti/min	
Stitch length	1.6~2.5 mm (standard 2.1 mm)	
Needle gauge	5.2, 6.0 mm	
Needle	FLx118GCS (#10S) #9S~#12S	
Retainer needle	FLG-8 (#8) #8~#11	



MF-3620



Please scan here to see a video

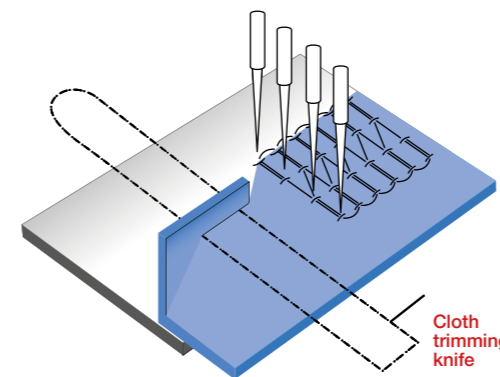

MF-3620L100 subclass is suited to a variety of different materials and has cloth trimmer on one side.

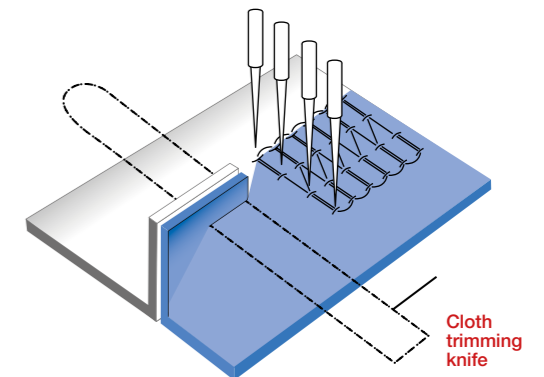

MF-3620L200 subclass is suited to light weight materials and has cloth trimmer on both sides.

Devices for MF-3620		
Item Name	Description	Item Number
40074700/40074164	Head Mount-Base and Space for MF-3620 (DD type A)	40074164
Autolifter	Pneumatic footlifter MF-3620	40074870
Chopper	Pneumatic chainoff cutter MF-3620	40074871
Suction	Pneumatic suction MF-3620	40074872

Item name	Item code
AIR HEMMER AH8 for H25	40176608
AIR HEMMER AH8_A	40173484
CURL PREVENTING BINDER (MF) AIR TYPE	70005385



CHAINSTITCH MACHINES

MH-481-5



MH-481



MH-484-5

(differential-feed)



MH-484

(differential-feed)



MH-486-5

(bottom and variabletop-feed)



1-needle, Double Chainstitch Machine

The machine comes with a thread spreading mechanism and an adjustable needle guard to prevent stitch skipping. The thread clamp mechanism, tension release mechanism and needle thread draw-out mechanism enable the machine to leave thread of a uniform length after thread trimming, and prevent slip-off of the needle thread. All of these mechanisms contribute to upgraded sewing.

Model name	MH-481-5, 481	MH-484-5, 484	MH-486-5
Max. sewing speed	5.500 sti/min		4.500 sti/min
Stitch length	1~4 mm	Main feed: 1~4 mm Differential feed: 1~5.6 mm	1~5 mm
Presser foot	By knee: 10 mm		By knee: 7 mm
Needle	TVx7 (#11) #9~#18		TVx7 (#11) #9~#21

MH-380

(parallel 2-needle)

MH-382

(tandem 2-needle)

High-speed, Flat-bed, 2-needle Double Chainstitch Machine

Accurate stitching performance and durable finished seams are particularly necessary in the chainstitching process. JUKI ensures high-quality sewing with a higher degree of consistency with its unique looper mechanism and consistent condensation stitching mechanism.

Model name	MH-380, 382
Max. sewing speed	6.000 sti/min
Stitch length	1~4 mm
Presser foot	By knee: 10 mm
Needle	TVx7 (#14) #9~#21



MH-481-5



MH-380, MH-382

MS-1261A DWS

High-speed, feed-off-the-arm, 3-needle double chainstitch sewing system (Digital workstation)

JUKI MS-1261A/DWS machine with low-tension sewing system produces high-quality seams with ease and consistency. Through improvements to the feed locus bending of the needle can be prevented. Machine is equipped with belt-type digital cloth puller, chain-off thread cutter, needle cooler, LED hand light as standard and an energy-saving high-powered direct-drive motor.

Model name	MS-1261A/ DWS	MS-1261AM/ DWS
Application	Heavy- ty extra heavy-weight	Medium- ty extra heavy- weight
Max. sewing speed	5.500 sti/min	
No. of needle	3	
Needle	UY130GS (standard) / Nm140 (#22)	
Feed	Bottom feed	
Needle gauge	33.2 mm	
Stitch length	1.4~4.2 mm	
Lift of the presser foot	10 mm	
Needle	UY128 GAS#16~#22 (Standart #21)	UY128 GAS#16~#22 (Standart #19)



MS-1261/ V045

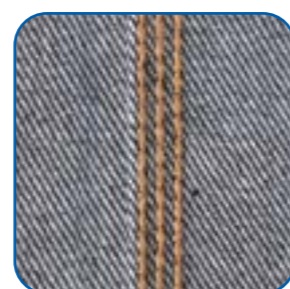

MS-1190



MS-1261

MS-1190

(2-needle, for light- to medium weight)



MS-1261

(3-needle, for heavy-weight)



Feed-off-the-arm, Double Chainstitch Machine

Thanks to the thread guide located between the needle bar thread take-up and the intermediate tension release lever, the timing to tense the needle thread can be decreased.

As a result, the machine is capable of beautiful stitches with a soft appearance even when heavy-weight material is used.

Model name	MS-1190	MS-1190M
Application	Light-weight	Medium-weight
Max. sewing speed	4.000 sti/min	
Needle gauge	3.2 mm (1/8")~6.4 mm (1/4")	
Stitch length	1.2~3.2 mm	
Needle	TVx64-NY (#12) #8~#14 B-64 (Nm80) Nm60~Nm90	TVx64-NY (#16) #12~#19 B-64 (Nm100) Nm80~Nm120

Model name	MS-1261M	MS-1261
Application	Medium- to heavy-weight	Extra heavy-weight
Max. sewing speed	3.600 sti/min	
Needle gauge	5.6 mm (7/32")~9.6 mm (3/8")	
Stitch length	1.4~4.2 mm	
Needle	UY128GAS-NY (#19) #16~#22 UY128GAS (Nm120) Nm100~Nm140	UY128GAS-NY (#21) #16~#22 UY128GAS (Nm130) Nm100~Nm140

MS-3580

Feed-off-the-arm, 3-needle Double Chainstitch Machine

This machine demonstrates increased feed efficiency to handle extra heavy weight 16-ply denim. Engineered with extra feeding strength for seaming the inside of jeans. The machine is best suited for lap seaming jeans, denim jackets, work uniforms, etc. constructed of heavy weight materials.

Model name	MS-3580S*1SN	MS-3580S*0SN
Application	Medium- to heavy-weight: jeans, denim jackets, work uniforms, etc.	
Max. sewing speed	4.500 sti/min	
Stitch length	2.1~3.6 mm (standard 3.2 mm)	
Needle	UY130GS (standard) / Nm140 (#22)	
Top feed roller width	11.9 mm	
Feed adjusting method	Main feed: Slide-type stitch -length adjusting method Differential feed: Lever adjusting method	Without the differential feed capability
Installation method	To be installed on the table by means of an auxiliary drive assembly MT03	



MS-3580S



MS-3580 is perfectly suited to sewing a variety of different seams in Jeans and other heavy weight materials.

MP-200N

Pinpoint Saddle Stitching Machine

The machine is able to perform sewing with a reduced tension applied to the thread, thereby widening its application range. With its upgraded responsiveness to changes in materials and processes, the machine always produces beautiful and soft pinpoint stitches.

Model name	MP-200NS
Max. sewing speed	2.000 sti/min (stitch length 6 mm or less)
Needle	SCHMETZ 29C150 (Nm90) Nm80~Nm140
	SCHMETZ 29C151 (Nm100) Nm80~Nm140
	Recommended yarn count #60~#30, B33~B46, Nm=120/3~60/3

Model name	MP-200NL
Max. sewing speed	1.500 sti/min (stitch length 6~8 mm)
Needle	ORGAN CPx1J (#22U) #18U~#22U
	ORGAN CPx12J (#23) #19~#23
	Recommended yarn count #30~#8, B46~B92, Nm=60/3~30/3



MP-200NL

CHAINSTITCH MACHINES

ML-111U

Single-thread, Chainstitch Basting Machine

Chainstitch is continuously formed with a single thread and by a blind looper which eliminates the need for a bobbin thread refilling. In addition, the basted seam can be easily undone.

Model name	ML-111U
Max. sewing speed	1.800 sti/min
Max. stitch length	10 mm
Presser foot	By knee: 12 mm
Needle	TVx7 (#14) #11~#14



ML-111U

Chainstich Devices

Item Name	Description	Item Number
AT27	Chain-off cutter MS-1190 MS-1261	GAT27000CA0
AT27	Chain-off cutter MS-1190V-045 MS-1261V-045	GAT27000DA0
AT27	Chain-off cutter MS-1190V-046 MS-1261V-046	GAT27000EA0
CL3	Needle Cooler MS-1190 MS-1261	GCL030000A0
CL3	Needle Cooler MS-1190 MS-1261 with auxiliary blower	GCL03000AA0
Silicon Unit	Silicon Thread Unit MS-1190	12945168
Silicon Unit	Silicon Thread Unit MS-1261	12976254
AK81	Pneumatic Footlifter Pedal Activate	GAK810000A0
AK81	Pneumatic Footlifter Knee-Sw Activate	GAK81000AA0

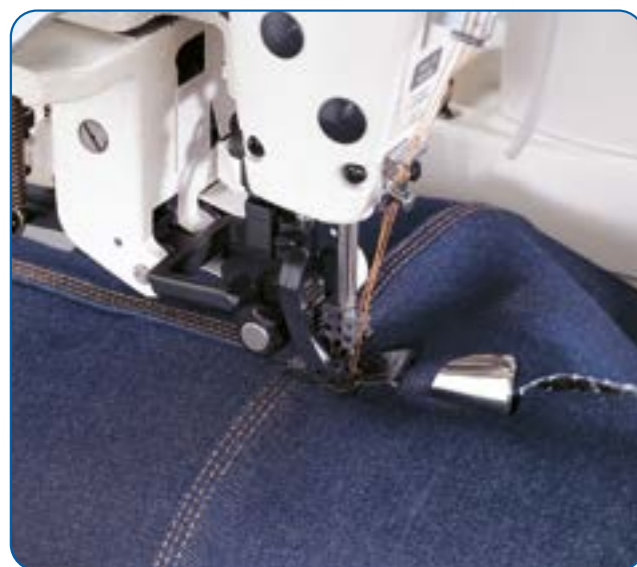

BUTTON SEWING MACHINES

BUTTON SEWING MACHINES

LK-1903BN

LK-1903BNS

(standard type)

LK-1903BNB

(shorter thread remaining functions)

LK-1903BNS/BR35

(with button feeder)

Computer-controlled, High-speed, Lockstitch, Button Sewing System

Users who are conscious about the finished quality of products manually nip, with scissors, the thread remaining on the material after thread trimming at the end of sewing. Now, the button sewing machine with the bird's nest preventing/shorter thread remaining functions saves such users the trouble of nipping the thread, thereby preventing the sewing product from being damaged by manual thread-nipping with scissors.

Data on sewing machine adjustments made according to the product to be sewn can be transferred to a commercially-available Android tablet in contactless mode. This enables quick check for uniform settings as well as confirmation of conditions of sewing machines in a sewing line, thereby facilitating setup changes. The operation panel is also provided as standard with a USB port. Data management and software update can be carried out with ease using a USB thumb drive.



LK-1903BN



Model name	LK-1903BNB	LK-1903BN	LK-1903,BN/BR35
Max. sewing speed	2.700 sti/min		
Button size	Type : Round-shaped, flat button Size : Ø8-Ø20 mm 301 : q,8,vq,20	Type : Round-shaped, flat button Size : Ø8-Ø32 mm 301 : Ø8-Ø20 mm 302 : Ø10-Ø20 mm OPTION : .Ø15-Ø32 mm	Size : Ø9-Ø20 mm For small button: Ø10-Ø15mm For medium-sized button: Ø12-Ø18 mm (Those that are smaller than Ø10 mm or larger than Ø18 mm must be specially ordered) Thickness: 1.8-3-5 mm
Stitch length	0.1-10 mm (0.1 mm step)		
Needle bar stroke	45.7 mm		
Lift of the work clamp foot	Max. 10 mm	Max. 13 mm	Max. 11 mm
Auto-lifter	Provided as standard (stepping motor type)		
Needle thread tension	Active tension (electronic thread tension control system)		
Needle (at the time of delivery)	DPx17 (#11)	DPx17 (#14)	
Hook	Standard shuttle hook		

The sewing machine eliminates so-called "bird's nests" (thread tangling in on the wrong side of the material at the beginning of sewing).

The thread is retained at the beginning of sewing and any excess thread is trimmed during sewing. As a result, the length of thread sewn in the seam is shortened, thereby achieving high-quality sewing performance while preventing thread from tangling in on the wrong side "of the material."

Length of thread remaining on the material at the end of sewing has been reduced to 2 mm or less*.

The newly-developed shorter-thread remaining mechanism trims the thread shorter after the regular thread trimming operation. Additionally, thread waste produced by thread trimming is withdrawn by suction. Thanks to this mechanism, the trouble of manual thread nipping is avoided.

Starting of sewing

Conventional lockstitch, button sewing machine



Bird's nest preventing



End of sewing

Conventional lockstitch, button sewing machine



Shorter thread remaining functions



LK-1903S

Computer-controlled, High-speed, Lockstitch, Simple Button Sewing Machine

The LK-1903S is Juki's new simple lockstitch button sewing machine. This model is in Juki Simple Series machine line with limited features but excellent sewing quality.

Model name	LK-1903S-SS
Application	Standard
Lubrication	Semi-dry head (Hook: minute-quantity lubrication)
Max. sewing speed	2.700 sti/min
Button size	Type: Round-shaped, flat button (2-holed, 4-holed) Size: ø8-ø32 mm 301: ø8-ø20 mm 302: ø10-ø20 mm OPTION: ø15-ø32 mm
Stitch length	0.1-10 mm (0.1 mm step)
Needle bar stroke	45.7 mm



BUTTON SEWING MACHINES

MB-1800A/BR10

(with button feeder)

MB-1800B

(with wiper unit)

Computer-controlled, Dry-head, High-speed, Single-thread, Chainstitch Button Sewing Machine

The machine is able to independently sew various stitching shapes such as U-shaped stitching, X-shaped stitching and Z-shaped stitching. The machine has 55 different stitching patterns as standard. In addition to the sewing shapes, the buttonhole intervals and number of stitches can also be changed on the operation panel.

Model name	MB-1800A/BR10	MB-1800B	MB-1800S
Max. sewing speed	1.800 sti/min		
Amount of feed	Crosswise feed 0~4.0 mm, Lengthwise feed 0~4.0 mm	Crosswise feed 0~10 mm, Lengthwise feed 0~6.5 mm	
Applicable buttons	Type: Round-shaped flat buttons Size: Ø10~Ø18 mm Size: Ø10~Ø28 mm		
Stitching shape	□, -, X, Z, □, -, I, △, ▽, ◁, ▷		
Button feed mode	Automatic feed mode, non-feed mode, and small-lot sewing mode	-	
Needle	TQx7 (#16) #14~#20		



MB-1800A/BR10



MB-1377

(quick stitch shape changing mechanism)

MB-1373

Single-thread, Chainstitch, Button Sewing Machine (thread-fray-prevention ON/OFF changeover mechanism)

The machine is provided as standard with a "thread-fray-prevention ON/OFF changeover mechanism" to help produce beautiful seams with added durability. Stitch shape can quickly be changed over between and button-hole configurations. (only for MB-1377)

Model name	MB-1377	MB-1373
Max. sewing speed	1.500 sti/min	
Number of stitches	8, 16, and 32 stitches	
Feed length (crosswise feed)	2.5~6.5 mm	
Feed length (lengthwise feed)	0~4.5 mm	0~6.5 mm
Stitching shape	□, X, -	□, -
Applicable button	Shank button, Wrapped-around button, Snap, Label, Metal button, Stay button (exclusive attachments have to be used)	
Button size	Ø10~Ø28 mm	
Thickness of button	1.8~3.5 mm (options max. 5 mm)	
Needle	TQx1 (#16) #14~20	



MB-1377

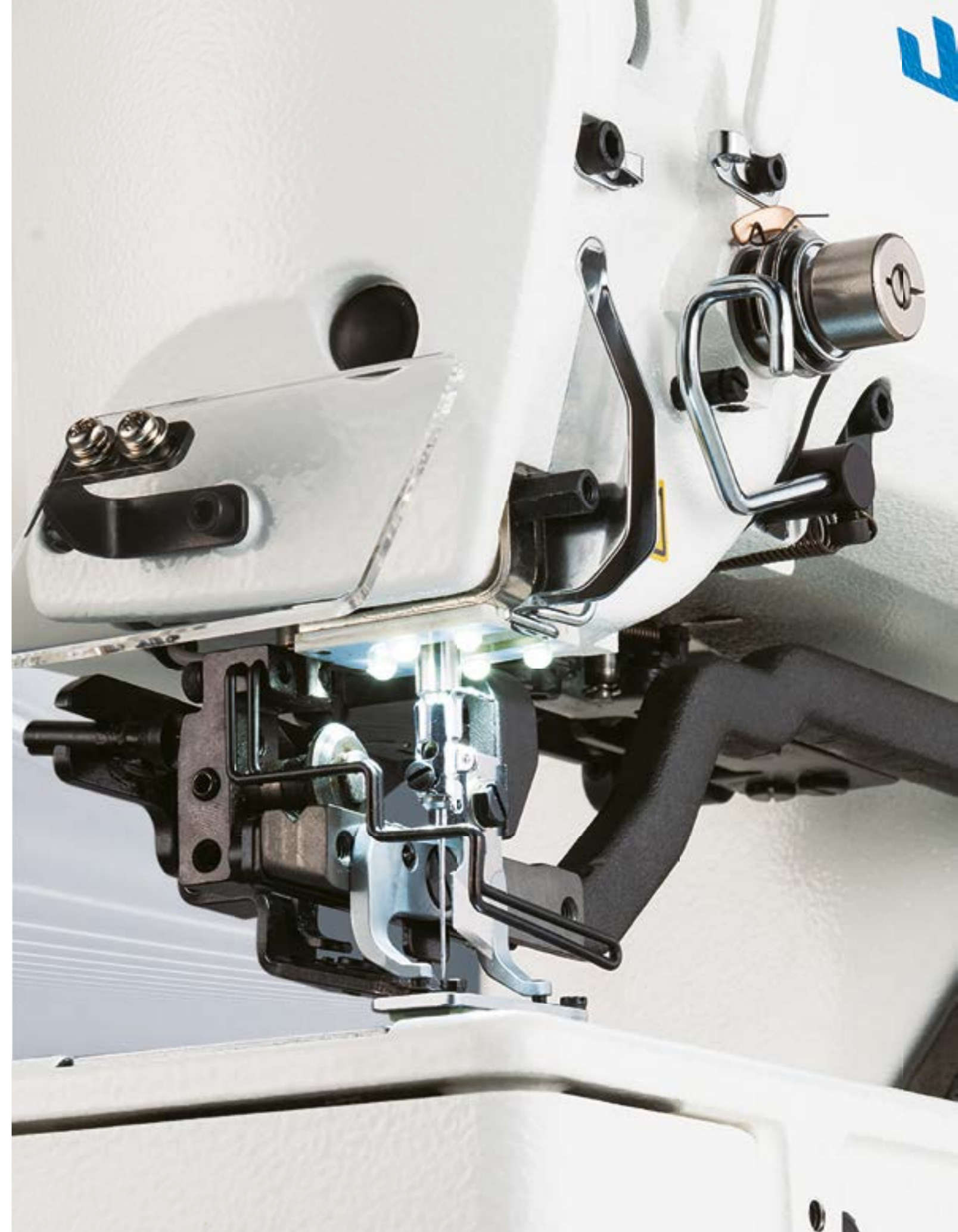

BUTTONHOLING MACHINES

BUTTONHOLING MACHINES

LBH-1790AN

(standard type)

LBH-1790ANB

(shorter remaining thread functions)

Computer-controlled, High-speed, Buttonholing Sewing System

The LBH-1790AN Series follows the world's highest sewing speed and dry-head mechanism of its predecessor model. In addition, this machine comes with the latest model operation panel which is installed with a USB port. Furthermore, all drive mechanisms have been digitalized to manage each sewing pattern individually. The maximum sewing speed is 4.200 sti/min., and the jump speed is 200 mm/s. The cycle time has been further reduced for continuous sewing.

Management of sewing performance and sewing machine by the utilization of IoT (Internet of Things)

Data on sewing machine adjustments made according to the product to be sewn can be transferred to a commercially-available Android tablet in contactless mode. This enables quick check for uniform settings as well as confirmation of conditions of sewing machines in a sewing line, thereby facilitating setup changes. The operation panel is also provided as standard with a USB port. Data management and software update can be carried out with ease using a USB thumb drive.

The length of remaining bobbin thread becomes shorter, less than 2.5 mm on average. The newly-developed shorter-thread remaining mechanism trims the thread short and eliminates the trouble of manual thread nipping.

Shorter-thread remaining functions

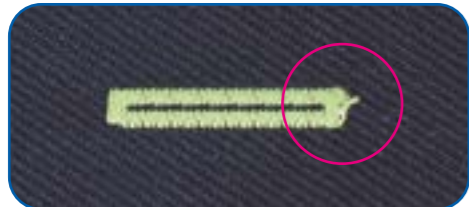

Conventional Buttonholing Machine

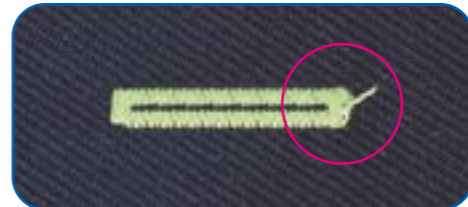

LBH-1790A



LBH-1790S

Computer-controlled, High-speed, Simple Buttonholing Sewing Machine

The LBH-1790S is the newest Juki button holing machine and latest addition to the Juki Simply Smart Series line up.

This model allows for the unrivaled quality one comes to expect with Juki but containing economical features. With a simple panel interface and powerful built-in motor it is one of the most reliable button holing machines available on the market today.



Powerful Motor



Simple panel

Model name	LBH-1790SS
Application	Standard
Lubrication	Semi-dry head (Hook: minute-quantity lubrication)
Max. sewing speed	4.200 sti/min (at the time of delivery: 3.600 sti/min)
Size of cloth cutting knife	6.4~31.8 mm (1/4"~1-1/4")
Buttonhole length	Max. 41 mm

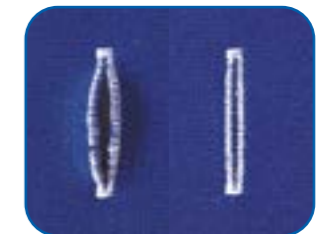

Basting Stitching

MEB-3200

Computer-controlled, Eyelet Buttonholing Machine (for men's and ladies wear)

The electronically controlled machine permits the selection and setting of various eyelet shapes. With its new technology called "active tension" (electronic thread tension mechanism), the machine is capable of duplicating the same sewing conditions with ease.

Model name	MEB-3200	MEB-3200RS
Thread trimming style	Longer remaining thread	
Sewing speed	400~2.200 sti/min (100 sti/min step)	
Feed length (crosswise feed)	2.5~6.5 mm	
Sewing length	10~38 mm (with thread trimmer) 10~50 mm (in case looper thread trimming device is removed) ¹	
Needle throwing wight	2~3.2 mm ²	
Taper bar length	0 mm, 3~15 mm	
Needle	DOX558 (Nm100) Nm90~Nm110	



LBH-782

Model name	LBH-1790ANB	LBH-1790AN	LBH-1795AN	LBH-1796AN
Sewing speed	Max. 4.200 sti/min, Normal 3.600 sti/min When the non-lubricated hook (optional) is used: 3.300 sti/min			
Needle bar stroke	34.6 mm			
Size of cloth cutting knife	6.4~22.2 mm (1/4"~7/8")	6.4~31.8 mm (1/4"~1-1/4")		6.4~25.4 mm
Bartacking width	Max. 4.0 mm	Max. 5.0 mm (with special-specification part: Max. 10 mm*)		Max. 5.0 mm
Buttonhole length	Max. 25 mm	Max. 41mm (optional: 70 mm, 120 mm)	Max. 120 mm	Max. 220 mm
Precision of needle throwing mechanism	0.05 mm			
Needle thread tension	Active tension (electronic thread tension control system)			
Number of stitches	Automatically computed from the size of the buttonhole and stitch pitch			
Needle (at the time of delivery)	DPx5 (#11J) #11J~#14J			
Hook	DP type, full-rotary hook Non-lubricated hook (optional)			

BUTTONHOLING MACHINES

MEB-3900

Computer controlled, Eyelet Buttonholing Machine

Then newly adopted direct-driven main shaft by means of a compact AC servomotor not only achieves enhanced responsiveness, but also achieves both reduced noise and reduced vibration. The MEB-3900 has been digitalized allowing for the easy programming and transfer of sewing parameters. Specifications that were normally manually adjusted can now be set numerically ensure accurate adjustment and exact reproduction across a machine line. Data can be edited either via the control panel or in the Juki Smart App for Android via NFC.



MEB-3900



Eyelet buttonhole

Buttonhole without a bartack	Buttonhole with a taper bar	Buttonhole with a straight bartack	Buttonhole with a round bartack

*Registered in standard patterns (J, C type)

Model name	MEB-3900N	MEB-3900C
Application	Jeans	Cotton pants and working wear
Stitch system	 Buttonhole without a bartack Buttonhole with a taper bar	 Buttonhole with a straight bartack Buttonhole with a round bartack
	The machine is provided as standard with 10 different stitching shape patterns of eyelet buttonhole. As many as 89 different patterns can be stored in memory and selected.	
Stitch system	1-needle, double chainstitch (with gimp)	
Sewing speed	400~2.500 sti/min	
Stitch length	10~38 mm (Needle thread trimming type) 10~34 mm (Overall thread trimming type)	

LBH-1790 Consumable Kits

LBH-1790A	Description	Quantity	
Kit P/N	40164483	Recommendable parts LBH-1790A	1 set
Construction Part Number	26261503	BTW Wheel rubber	1
	26261602	Bobbin spring	1
	10006104	Take-up spring	2
	13729066	Hook assortment	3
	13729769	Bobbin case assortment	1
	40009148	Bobbin	3
	B1552781000A	Work clamp check	1
	SM7000550TP	Screw M3 L=4.5	1
	13706403	Needle bar bobbin thread guide	1
	40004311	Bt trimmer	1
	40027553	Throat plate (1790S5)	1
	13727102	Stopper	1
	40004346	Picker	1
SM6050802TP	Screw M5X0.8 L=8	1	
B2702047LOOA	Knife 1/2	1	

LBH-1790A (Knit Specification)	Description	Quantity	
Kit P/N	40164483	Knit parts LBH-1790A	1 set
Construction Part Number	13782065	Hook assortment	1
	13782107	Hook timing gauge	1
	D1511772KAO	World clamp check holder	1
	D1511772KOO	World clamp check (2K)	1
	SS60621OSP	Screw 3/32-56 L=1.9	2
	40027554	Throat plate (1790K5)	1





BARTACKING MACHINES

LK-1900BN
(standard type)

LK-1900BNB
(shorter remaining thread functions)

Computer-controlled, High-speed, Bartacking Sewing System

Thanks to the Bird's nest preventing / shorter-thread remaining functions, manual thread-nipping is no longer required.

Management, browsing and editing of data can be carried out on the application software. Data on sewing machine adjustments made according to the product to be sewn can be transferred to a commercially-available Android tablet in contactless mode. This enables quick check for uniform settings as well as confirmation of conditions of sewing machines in a sewing line, thereby facilitating setup changes. The operation panel is also provided as standard with a USB port. Data management and software update can be carried out with ease using a USB thumb drive.



LK-1900 BNB



Management of sewing performance and sewing machine by the utilization of IoT (Internet of Things)

Management, browsing and editing of data can be carried out on the application software.

Data on sewing machine adjustments made according to the product to be sewn can be transferred to a commercially-available Android tablet in contactless mode. This enables quick check for uniform settings as well as confirmation of conditions of sewing machines in a sewing line, thereby facilitating setup changes. The operation panel is also provided as standard with a USB port. Data management and software update can be carried out with ease using a USB thumb drive.

Data items of sewing can be numerically managed to ensure "stable quality" and "reduction in time required for setup changes". Quantified sewing data can be externally taken from the sewing machine using an Android tablet or USB thumb drive.



Model name	LK-1900BN-SS	LK-1900BN-HS	LK-1900BN-FS	LK-1900BN-WS	LK-1900BN-BS
Application	Standard	For heavy-weight materials	For foundation	With large hook for heavy-weight materials	Standard
Max. sewing speed	3,200 sti/min*			2,700 sti/min*	3,200 sti/min*
Sewing area	30 mm (L) x 40 mm (W)				
Stitch length	0.1~10 mm (0.1 mm step)				
Needle bar stroke	41.2 mm				
Lift of the work clamp foot	Standard 14 mm (17 mm when the reverse-rotation needle-up function)				Standard 11mm (by using the reverse-rotation needle-up function 14mm)
Auto-lifter	Provided as standard (stepping motor type)				
Needle thread tension	Active tension (electronic thread tension control system)				
Needle (at the time of delivery)	DPx5 (#14)	DPx17 (#21)	DPx5 (#11)	DPx17 (#21)	DPx17 (#14)
Hook	Standard shuttle hook			Large shuttle hook	Standard shuttle hook

BARTACKING MACHINES

LK-1900S

Computer-controlled, High-speed Simple Bartacking Machine

The LK-1900S is Juki's new simple bartack sewing machine. This model is in Juki Simple Series machine line with limited features but excellent sewing quality.



SIMPLY
smart solution



Model name	LK-1900S-SS	LK-1900S-HS
Application	Standard	For heavy-weight materials
Lubrication	Semi-dry head (Hook: minute-quantity lubrication)	
Max. sewing speed	3.200 sti/min (at the time of delivery: 2.700 sti/min)	
Sewing area	30 mm (L) x 40 mm (W)	
Stitch length	0.1~10 mm (0.1 mm sted)	

LK-1920

(with intermediate preser)

LK-1930

(with intermediate presser and input function)

Computer controlled, High-speed Shape-tracking Machine

The machine is fully equipped with state-of-the-art features such as a higher presser foot lift, a double-capacity shuttle hook and a direct control machine head that ensures quick response and accurate stop position.

Model name	LK-1920S	LK-1920H
Application	Standard	Heavy-weight
Sewing area	60 mm (L) x 100 mm (W)	
Max. sewing speed	2.500 sti/min	
Stitch length	LK-1910,20: 0.1-12.7 mm	
Number of data that can be input	LK-1910,20: 64 patterns LK-1930: 691 patterns	
Needle	DPx5 (#14), DPx17 (#18)	



LK-1930

Bartacking Machine Devices

Item	Description	Spare part number
FU02S	360 device for LK-1920 and LK-1930 S-type	83007369
FU02L	360 device for LK-1920 and LK-1930 A-type	83007351
Third Tension	Third Thread Tension LK-1910, LK-1920, LK-1930, LK-1941, LK-1942	B50192220B0
Needle Cooler	Needle Cooler device LK-1910, LK-1920, LK-1930, LK-1941, LK-1942	14225056
Simple Work Clamp	Simple work clamp kit	40057279
Tension Release	Tension Release LK-1910, LK-1920, LK-1930, LK-1941, LK-1942	14224760
1-Pedal PK57	PK57 1-Pedal	GPK57001B0
1-Pedal PK57 Conn.	PK57 Wiring Unit	M90135900A0
2-Pedal Unit	2-Pedal Unit	M85205800A0
2-Pedal Unit Conn.	2-Pedal Unit Wiring Unit	M90125900A0
PGM7	Handheld programmer LK-1941, LK-1942	PGM7
Third Tension	Third Thread Tension LK-1910, LK-1920, LK-1930, LK-1941, LK-1942	B50192220B0
Needle Cooler	Needle Cooler device LK-1910, LK-1920, LK-1930, LK-1941, LK-1942	14225056
Tension Release	Tension Release LK-1910, LK-1920, LK-1930, LK-1941, LK-1942	14224760
Thread Burner	Thread Burner LK-1942	14447056
Reverse Wiper	Reverse Wiper LK-1941, LK-1942	14446009
Reverse Wiper Base	Reverse Wiper Base LK-1941, LK-1942	14445902
Silion Tank	Silicon Oil Tank LK-1941, LK-1942	B92118500A0
3-Pedal PK47	3-Pedal Unit for AMS	GPK470010AB
3-Pedal PK47 Conn.	PK47 Wiring Unit for LK-1941, LK-1942	M90255800A0



Bartacking Machines Consumable Kits

LK-19008				LK-1900B (Knit Specification)			
Kit P/N	Description	Qty		Kit P/N	Description	Qty	
40164796	Recommendable_parts_lk1900b(s)	1 set		40164797	Recommendable_parts_lk1900b(h)	1 set	
26261503	Blw wheel rubber	1	Construction Part Numbers	26261503	Btw wheel rubber	1	Construction Part Numbers
40010574	Thread guide	1		D1405L7AMOO	Needle bar thread guide	1	
B18289800BB	Bobbin case asm. (Racing preve)	1		B18289800BB	Bobbin case asm. (Racing preve)	1	
13812102	Bobbin	3		13812102	Bobbin	3	
40110846	Shuttle	1		40112995	Shuttle	1	
22921605	Thread take-up spring	2		22921605	Thread take-up spring	2	
SS1060210TP	Screw 3/32-56 l=2.2	1		SS1060210TP	Screw 3/32-56 l=2.2	2	
B2426280000	Needle hole guide	1		14109607	Needle hole guide	1	
B2424280000	Fixing knife	2		82424280000	Fixing knife	2	
B24212800AO	Moving knife asm.	1		B24212800AO	Moving knife asm.	1	



COMPUTER-CONTROLLED CYCLE MACHINES

AMS-221F-2516

(X: 250 mm x Y: 160 mm)

AMS-221F-3020

(X: 300 mm x Y: 200 mm)

Computer-controlled Cycle Machine with Input Function



NEEDLE-THREAD ACTIVE TENSION

Needle thread active tension which matches sewing conditions given can be set on the operation panel and stored in memory

ACTIVE PRESSER FOOT PRESURE

The material thickness is automatically detected and the height of the presser foot is automatically raised or lowered

NON-MAGNETIC THROAT PLATE

Presser foot and sewing performance not interfered with by magnetic resistance

NEW IP-500 PANEL

NFC data transfer and digital adjustments are possible directly via the panel



AMS-221F has achieved increased productivity with its maximum sewing speed of 2,800 sti/min and beautifully finished seams with its new feed control system. The active tension can be changed over with the memory switch between the low-tension side output and the high-tension side output to enable fine adjustment of the thread tension in the actual area of use.

Management, browsing and editing of data can be carried out on the application software

A "Two-way" contactless communication for parameter adjustment data can be conducted with the sewing machine by a commercial Android terminal. This feature allows sewing machines in a sewing line to be uniformly set and status checked quickly, thereby contributing to stabilization in product quality. Control panel is standardized with USB ports, promising simplicity in data management and system updates.



Model name	AMS-221F-S	AMS-221F-H	AMS-221F-G
Application	Light-to medium-weight	Medium-to heavy-weight	Heavy-to Extra heavy-weight
Max. sewing speed	2,800 sti/min		
Sewing area	0.1~12.7 mm (0.05 mm step)		
Storage of pattern data in the memory	Main-body memory: Max 50,000,000 stitches, 999 patterns (max 50,000 stitches / pattern)		
	External media: Max 50,000,000 stitches, 999 patterns (max 50,000 stitches / pattern)		
Needle	DPx5 (#14)	DPx17 (#18)	DPx17 (#23)

COMPUTER-CONTROLLED CYCLE MACHINES

AMS-210EN-1510

(X: 150 mm × Y: 100 mm)

The 1510 model is well received in the market due to its moderate sized sewing area. Responding to market demand, the 1510 area model with a motor-driven feeding frame has been newly developed. This model can be used in a plant which is not provided with pneumatic equipment.



AMS-210EN-1510

AMS-210EN-1306

(X: 130 mm × Y: 60 mm)

AMS-210EN-1510

(X: 150 mm × Y: 100 mm)

AMS-210EN-2210

(X: 220 mm × Y: 100 mm)

Computer-controlled Cycle Machine with Input Function

The sewing machine achieves the highest sewing speed, 2,800 sti/min, in the industrial sewing machine industry. As a result, cycle time is dramatically reduced. The feed accuracy is substantially improved due to the adoption of the encoder control system. The new AMS Series models substantially decrease power consumption when compared with the conventional ones. They have been designed to achieve eco-friendliness.

AMS-210EN-1306

(X: 130 mm × Y: 60 mm)

The sewing machine flexibly supports the sewing of small articles such as labels and emblems. The sewing machine's small sewing area promises ease of use when handling small articles, thereby enabling smooth sewing operation.

AMS-210EN-2210

(X: 220 mm × Y: 100 mm)

This model has a sewing area that is best-suited to the sewing of large parts, including the shape-tacking of jean pockets. With this model, you may recognize the higher productivity of the cycle machine.

AMS-221EN-2516

(X: 250 mm × Y: 160 mm)

AMS-221EN-2516

(X: 250 mm × Y: 160 mm)

The sewing machine is best-suited to the sewing of large labels and emblems, the sewing of two or more pieces of small labels and emblems at one time, and the shape-tacking of bags and shoes.

AMS-221EN-3020

(X: 300 mm × Y: 200 mm)

It is best-suited to the attaching of handles to bags and the shape-tacking of boots and shoes. The sewing machine is flexibly applicable to sewing requiring a medium sewing area.



AMS-221EN-2516

Model name	AMS-210EN-SS	AMS-210EN-HS	AMS-221EN-SL	AMS-221EN-HL
Application	Light- to medium-weight	Medium- to heavy-weight	Light- to medium-weight	Medium- to heavy-weight
Max. sewing speed	2,800 sti/min*			
Stitch length	0.1~12.7 mm (0.05 mm step)			
Storage of pattern data in the memory	Main-body memory: Max. 500,000 stitches, 999 patterns (max. 50,000 stitches / pattern) External media: Max. 50,000,000 stitches, 999 patterns (max. 50,000 stitches / pattern)			
Needle	DP×5 (#14)	DP×17 (#18)	DP×5 (#14)	DP×17 (#18)

*Stitch length is 4 mm or less for the AMS-210EN and 3.5 mm or less for the AMS-221EN.

AMS-221EN-HS3020/7200

Computer-controlled Cycle Machine with Input Function (for sewing pockets on jeans)

This model is designed for sewing pockets on jeans and is based on the AMS-221EN Series. AMS-221EN-HS3020/7200/SS46 (SS46 stacker is optionally available). The machine achieves excellent seam quality by the use of the "active tension" and the "intermediate presser height adjusting function". The retractable pocket clamp plate is adopted. This feature can be used for the inner stitches of double-line sewing. In addition, since the travel stroke of the pocket clamp plate is adjustable according to the pocket size, pockets can be sewn beautifully with no sewing trouble regardless of the pocket size.

* The size of the clamp will effect the minimum pocket size that can be sewn.

Model name	AMS-221EN-HS3020/7200
Application	Heavy-weight
Feeding frame type	
Max. sewing speed	2,000 sti/min
Sewing area	X: 246 mm × Y: 200 mm
Stitch length	0.1~12.7 mm (0.05mm step)
Needle thread tension	Active tension (electronic thread tension control mechanism)
Needle	DPx17(#19)
Hook	Double-capacity shuttle hook



AMS-221EN-HS3020/7200

AMS-221EN-TS3020

(X: 300 × Y: 200mm)

Computer-controlled Cycle Machine with Input Function (for 2-colour-thread sewing)

This machine (AMS221EN-TS) has been developed to enable two colour stitching (with two kinds of thread which are different in colour).

Possible difference in position of the sewing product which can be caused by re-placing it on the sewing machine in a different process is eliminated, thereby increasing the productivity. It is suitable for sports shoes, bags and car seats such as the topstitch and parts sewing, etc.

Model name	AMS-221EN-TS3020
Max. sewing speed	2,500 sti/min
Stitch length	0.1~12.7 mm (0.05 mm step)
Storage of pattern data in the memory	Main-body memory: Max. 500,000 stitches, 999 patterns (max. 50,000 stitches/pattern) External media: Max. 50,000,000 stitches, 999 patterns (max. 50,000 stitches/pattern)
Needle	DP×17 (#18)



AMS-221EN-TS3020

AMS-221EN-TS3020/X90004

Computer-controlled Cycle Machine with Input Function (for 2-colour-thread sewing pockets on jeans)

This model is designed for 2-colour-thread sewing pockets on jeans and is based on the AMS-221EN Series. The machine sews folded pocket cloth on the garment body.

The folded pocket clothe can be made with the JEUX0021 creasing machine. These two machines work in perfect combination; for more information see 'other' section in this catalogue.

Model name	AMS-221EN-TS3020/X90002
Max. sewing speed	2.500 sti/min
Sewing area	Max. 110 mm x 110 mm Min. 90 mm x 90 mm
Stitch length	0.1~12.7 mm (0.05 mm step)
Storage of pattern data in the memory	Main-body memory: Max. 500.000 stitches, 999 patterns (max. 50.000 stitches/pattern)
	External media: Max. 49.950.000 stitches, 999 patterns (max. 50.000 stitches/pattern)
Needle	DPx17 (#21) #18~#21



AMS-221EN-TS3020/X90002

AMS-224EN-4530

(X: 450 mm x Y: 300 mm)

AMS-224EN-6030

(X: 600 mm x Y: 300 mm)

Computer-controlled Cycle Machine with Input Function

The machine achieves the highest sewing speed of 2.500 sti/min among those with a similar sewing area. With its higher productivity, the machine performs various kinds of stitching, making the most out of its wider sewing area in various sewing applications such as attaching handles to bags and pouches, attaching belts, sewing many small parts at a time, attaching parts to shoes and sports shoes (one pair of shoes) and sewing air bags.

Model name	AMS-224EN-HS	AMS-224EN-GB
Application	Medium- to heavy-weight	Extra heavy-weight
Max. sewing speed	2.500 sti/min (stitch length 3 mm or less)	
Settable stitch length	0.1~12.7 mm (0.05 mm step)	
Storage of pattern data in the memory	Main-body memory: Max. 500.000 stitches, 999 patterns (max. 50.000 stitches/pattern)	
	External media: Max. 50.000.000 stitches, 999 patterns (max. 50.000 stitches/pattern)	
Needle	DPx17 (#18)	DPx17 (#23)



AMS-224EN-6030



Please scan here to see a video

AMS-221EN-SS3020/72001764

Polo-shirts Placket Automated Sewing Workstation

Computer-controlled Cycle Machine with Input Function (Polo shirts Placket Device). The device is able to place a placket on garment body while the machine is still engaged in the sewing of the current placket. This means higher productivity can be achieved with one machine. The machine can sew V-shape stitch, and Dimple-shaped depression automatically creating less work then when it is done manually.

Model name	AMS-221ENSS3020/Polo-shirts Placket Device
Sewing area (hidden placket for men)	X: 4~6 mm x Y: 180 mm
Placket cloth size	90~130 mm (W) x 200 mm (L)
Max. sewing speed	2.500 sti/min*
Application	Medium-weight
Needle (Recommendation)	DPx17(#9~#11)
Thread	#60~#50



AMS-221ENSS3020/Polo-shirts Placket Device

Alternative models

Model Name	LBH1796AS/X73223	AMS-221ENHS3020/PP220
Part number	40177344	Complete
Placket type	Single Placket	Single Placket
Cycle type	16 sec	19 sec
Model Name	AMS-221ENHS3020/PP110	AMS-221ENHS3020/PP120
Part number	72005200	40178676
Placket type	Single Placket Top Stitch	Double Placket Dual Top Stitch
Cycle type	21 sec	31 sec

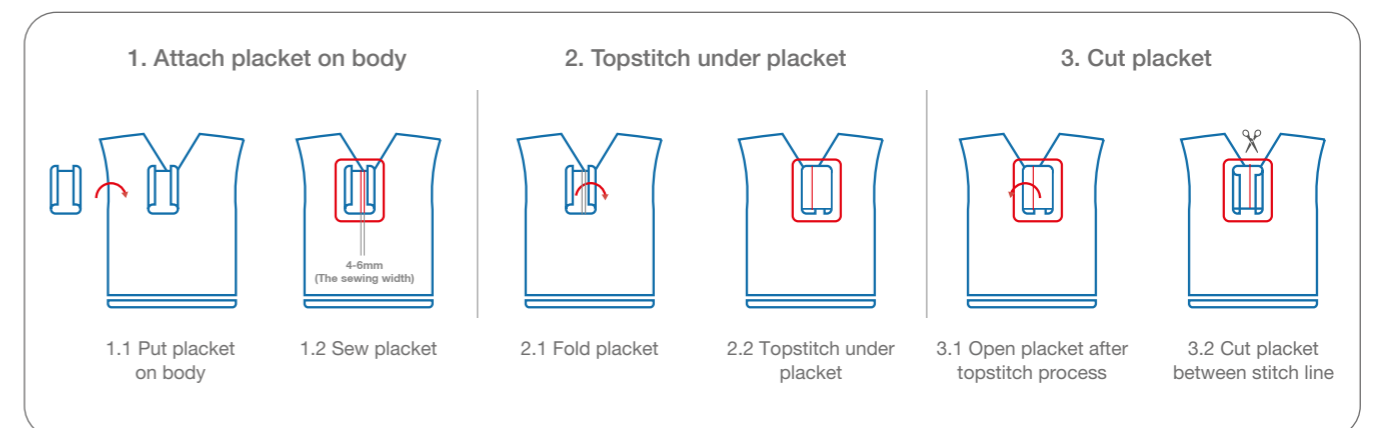

COMPUTER-CONTROLLED CYCLE MACHINES

AMS-224EN6030/X7910

(X: 600 mm x Y: 300 mm)

AMS-221EN2516/X7910

(X: 250 mm x Y: 160 mm)

Computer-controlled Cycle Machine with an Input Function (For Total-area Perfect Stitching)

AMS-224EN(AMS-221EN)/X7910 has removed the area where hitch stitches are produced to make the total area capable of sewing with perfect stitches, thereby improving the seam quality. Stitch knot formation has been developed so that the needle thread and the bobbin thread are at proper right angle resulting in flawless stitches. The machine comes with a double-capacity shuttle hook ideally suited for Total-area perfect stitching. This shuttle hook ensures a consistent thread tension by preventing the thread from being untwisted by its rotation.

Model name	AMS-221EN2516/ X7910	AMS-224EN6030/ X7910
Sewing area	250 mm (X) x 160 mm (Y)	600 mm (X) x 300 mm (Y)
Max. sewing speed	1,500 sti/min (stitch length 6 mm or less)	
Settable stitch length	0.1~12.7 mm (0.05 mm step)	
Lift of the feeding frame	Max. 30 mm	
Needle (at the time of delivery)	DPx17 (#18)	
Thread	#50-#2	
Hook	Double-capacity shuttle hook	

Specifications that are not given above shall conform to those for the AMS-224EN and AMS-221EN.



AMS-224EN6030/X7910

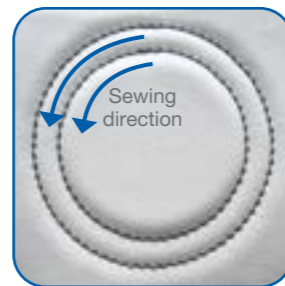

AMS-224EN(AMS-221EN)/X7910 can produce perfect stitches regardless of the sewing directions.

AMS-221EN/JEUX0043

AMS-221EN/X7910/JEUX0043

(perfect stitch type)

AMS-224EN/JEUX0043

AMS-224EN/X7910/JEUX0043

(perfect stitch type)

Computer Controlled Cycle Machine with extension size available from X: 600-2100 mm, Y: up to 575 mm

Juki's AMS 221 and 224 series is now available with an extended sewing area in a variety of different dimensions. The wider sewing area means the machine is new better suited to the sewing of decorative stitches on car seats. The machine not only achieves higher productivity due to instantaneous increases/decreases in sewing speed at the beginning/end of sewing and increased of thread trimming speed, but also achieves a flexible responsiveness to materials to promise enhanced seam quality due to JUKI's unique active tension and programmable intermediate presser.



AMS-221EN-3020



PS-700

Computer Controlled Cycle Machine with extension size available from X: 1200 mm x Y: 700 mm

PS-700 is a pattern seamer provided with JUKI's first exclusive machine head. It is able to carry out pattern sewing of large products with flexibility. The PS-700 has achieved the industry's highest jump speed of 800 mm/s. Active tension has been introduced to the needle thread tension controller. Since the needle thread tension is reproducible, supporting a broader range of sewing conditions, the time required for setup changing upon process changeover can be reduced.

Model name	PS-700
Maximum sewing speed	3,000 sti/min
Jump speed	800 mm/s
Possible sewing area	Width (X) 1,200 mm x Length (Y) 700 mm
Stitch length	0.1 - 12.7 mm (in increments of 0.1 mm)
Needle bar stroke	39.8 mm
Needle thread tension	Active tension (computer-controlled thread tension control mechanism)
Needle	DBx1 (#9 to #16)
Hook	Full-rotary double-capacity hook



PS-700

PS-800-12080

Sewing area
1,200 mm (X) x 800 mm (Y)

PS-800-8045

Sewing area
800 mm (X) x 450 mm (Y)

Computer Controlled Cycle Pattern Seamer with optional material cutter

The PS-800 is Juki's newest computer controlled pattern seamer and now in 2 new sewing area sizes. The machine has dry head technology but also allow for a max sewing speed of 3000 sti./min. This pattern seamer has the ability to add an optional material cutter. This optional cutter can be a straight knife, rotary knife or laser cutter depending on the requirements of your production and the material to be used.

An RFID reader is provided as standard, ensuring the correct clamp is used avoiding operator loading errors/.

Model name	PS-800SS12080/ PS-800HS12080	PS-800SB8045/ PS-800HB8045
Sewing area	1,200 mm x 800 mm	800 mm x 450 mm
Feeding type	Double Guide-rail drive	Double stepping motor Belt Drive
Max. sewing speed	3,000 sti/min	
Stitch length	0.5 - 12.7 mm	
Hook	Full-rotary double-capacity hook	



PS-800

COMPUTER-CONTROLLED CYCLE MACHINES

Part number	Description
FU07 (40092951)	360 device for AMS-EN
Needle Cooler (40092717)	Needle Cooler device for AMS-EN
Needle Cooler (40035962)	Needle Cooler device for AMS-EN to use with swing wiper
Air Kit (40089848)	Pneumatic Connection Kit for AMS-EN#S type with FU07
Swing Wiper (40035867)	Thread wiper side-swing type
Cable (B4150210DA0)	Relay cable asm., for swing wiper AMS-210EN
Cable (40036668)	Relay cable asm., for swing wiper AMS-221EN
Cable (40080837)	Relay cable asm., for swing wiper AMS-224EN
Quick Changer (40089692)	Quick changer clamp for AMS-210EN#S type
Quick Changer (40089695)	Quick changer clamp for AMS-210EN#L type
Quick Changer (40052330)	Quick changer clamp for AMS-221EN-HL2516
Cassette Clamp (B2953210DA0)	Cassette Clamp for AMS-210EN-1306
Cassette Clamp Base (B2594210DA0)	Cassette Clamp Base for AMS-210EN-1306
Cassette Clamp (B25822210A0)	Cassette Clamp for AMS-221EN-2516
Cassette Clamp Base (40052328)	Cassette Clamp Base for AMS-221EN-2516
Cassette Clamp (40053777)	Cassette Clamp for AMS-221EN-3020
Cassette Clamp Base (40053782)	Cassette Clamp Base for AMS-221EN-3020
Cassette Clamp (40072202)	Cassette Clamp for AMS-224EN-4530
Cassette Clamp Base (40072197)	Cassette Clamp Base for AMS-224EN-4530
Cassette Clamp (40072204)	Cassette Clamp for AMS-224EN-6030
Cassette Clamp Base (40072215)	Cassette Clamp Base for AMS-224EN-6030
Blank Bottom Plate (40072149)	Metal Feed Plate Blank for AMS-224EN-4530
Blank Bottom Plate (40072150)	Metal Feed Plate Blank for AMS-224EN-6030
Label Setter (40102007)	Label setting device for AMS-210EN-HL1306
Two Stroke (40042352)	Two Stroke Kit for AMS-210EN#L type
Third Tension (40072310)	Third Thread Tension for AMS-EN
Milling Unit (MU11X70358)	Milling Unit for AMS-224EN
Barcode Reader (40089238)	Barcode Reader for AMS-EN
Pocket Setter (40065540)	Pocket setting device for AMS-210EN-3020
3-Pedal PK47 (GPK470010AB)	3-Pedal Unit for AMS
3-Pedal PK47 Conn. (40033875)	PK47 Wiring Unit for AMS
PM3 (40101930)	PM3 Embroidery Software
Movable inverter clamp (72002808)	Movable Inverter Clamp for AMS-210EN-1306
Movable inverter clamp (72002809)	Movable Inverter Clamp for AMS-210EN-1510
Label presser foot (72003196)	Label Presser Foot for AMS
Clamp S Type (40134010)	Auto Eject One-Touch type Clamp for AMS
Cassette base (40137793)	Cassette Base for AMS-224EN-4530
Cassette base (40137794)	Cassette Base for AMS-224EN-6030
Cassette base (40151575)	Cassette Base for AMS-221EN-3020
Polo Placket Unit (72005368)	Single-type Polo Placket Sewing Unit for AMS-221EN-3020
Polo Placket Unit (72005638)	Double-type Polo Placket Sewing Unit for AMS-221EN-3020
Conversion Kits for AMS221ENHS3020SZ/7200NSD	Pocket Setter Clamp Set
JEUX0021	Jeans Pocket Creaser, Electronic Heater
JEUX0021-JIG	Jig Set for JEUX-0021

Computer-controlled Cycle Machine



AUTOMATIC MACHINES

APW-895NS

(for straight pockets with flaps)

APW-895NL

(for straight pockets with flaps)

APW-896N

(for slanted pockets)

Lockstitch, Automatic Welting Machine

The machine supports the sewing of straight pockets (with flaps) on suits, jackets and pants. Double-/single-welt sewing can be changed over by the simple touch of a key on the operation panel. *The "direct-drive motor", which transfers the motor power to the machine with no energy loss, not only offers economical benefits due to the power reduction, but also reduces the machine's vibration and operating noise, thereby helping reduce operator fatigue.

*The machine head is provided with a semi-dry head to eliminate staining with oil from the frame (the needle bar part).

– The support of long and wide welts is enriched, the machine can sew large-sized pockets such as pockets on coats.

(APW-896)

In addition to the APW-895NS's functions, the APW-896NL supports the sewing of slanted pockets (for sewing slanted flaps). The world's first computer-controlled sidewise cutting position of the corner knives enables easy adjustments of the knives simply by operating the panel.

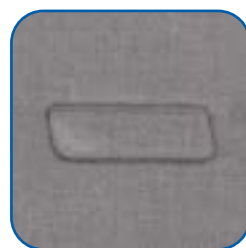

Ability to sew slanted pockets and flaps



APW-896N

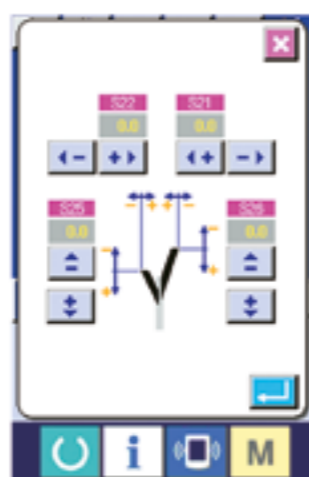

The cutting of the corner-knife can be adjusted through the operation panel



Please scan here to see a video

Model name	APW-895NS	APW-896N
Flap type	Rectangular flap	Rectangular / Slanted flap
Sewing speed	Max. 3.000 sti/min (1.000-3.000 sti/min)	
Kind of welts	Parallel double welt, parallel single welt (with/without flaps)	Parallel double welt, parallel single welt, slanted double welt, slanted single welt, trapezoidal sewing (with/without flaps)
Stitch length	Standard 2.5 mm (2.0-3.4 mm)	
Stitch length (fastening stitching)	Condensation stitching: Standard 1.0 mm (0.5-1.5 mm) Back-tack stitching: Standard 2.0 mm (0.5-3.0 mm) *Changeable between condensation / back-tack stitching	
Corner-knife cutting adjusting method	Mechanical adjustment	Electronic adjustment
Needle	ORGAN DPx17 Standard #16 (#14-#18), SCHMETZ 190R Standard #100 (#100-#110)	
Number of independent sewing patterns	99 patterns (999 patterns when a CF memory card is used)	
Number of cycle sewing patterns	20 patterns	
Number of alternate sewing patterns	20 patterns	
Machine Head	2-needle, lockstitch machine (LH-895)	2-needle, lockstitch machine with organized split needle bar (LH-896)
Cloth feeding system	Driven by a stepping motor	
Power requirement	Single-phase 200-240V, 3-phase 200-380V 50Hz / 60Hz	
Power consumption	350VA	
Compressed air / Air consumption	0.5 MPa, 40 dm ³ /min (ANR)	
Weight	238,5 Kg	259,0 Kg
Dimensions	1.095 mm(W) x 1.500 mm(D) x 1.200 mm(H) (Width 1580 mm = Stacker included) (Height 1800 mm = Thread stand included)	

AP-876

(full-automatic)

Jeans Pocket Setter

The machine automatizes a series of pocket setting processes such as the folding of a pocket, placement of the pocket on a garment body, sewing, bar tacking and stacking, thereby increasing productivity and achieving production without requiring the operator to have any special skill. This promises consistent finished quality.

AP-874

(semi-automatic)

This sewing machine is a semi-automatic type pocket setter. The sewing machine has been specifically designed for sewing pockets which have been preliminarily folded in the preceding process on a predetermined location of the garment body without folding the pocket cloths.

Model name	AP-876	AP-874
Application	Full-automatic	Semi-automatic
Machine head	High-speed, 1-needle, lockstitch, zigzag stitching machine (exclusive machine head)	
Max. sewing speed	4.000 sti/min	
Sewing area	250 mm x 250 mm	
Stitch length	0.1-6 mm	
Operation panel	IP-420 (large-sized colour liquid crystal touch panel)	
Storage of pattern data in the memory	Max. 999 pattern	

AB-1351

Automatic 1-needle Belt-Loop Attaching Machine

AB-1351 is belt-loop attaching machine with the ability to solely sew 12 different belt-loop sewing patterns! This machine not only reduces the time required for the belt-loop attaching process, but also achieves labor-saving, such as the elimination of the previous process (belt-loop cutting). Productivity can be dramatically increased when one operator attends to two AB-1351 units.

Available also new model: AB-1360/CR-10A Automatic 1-needle shoelace loop attaching machine provided with a preset loader. It's an automatic sewing machine which is ideally suited for sewing shoelace loops of sports shoes.

Model name	AB-1351
Machine head	LK-1961/ABH (Exclusive machine head based on the LK-1900A, Semi-dry-head)
Max. sewing speed	2.500 sti/min
Stored bartacking patterns (Stitches)	Linear bartacking (12, 15, 21, 28, 36, 41) / Zigzag bartacking (28, 36, 42, 56, 64)
Bartacking size length-wise	0~3.2 mm (0"~1/8") (adjustable in increments of 0.1 mm)
Bartacking size cross-wise	6~23 mm (15/16"~57/64") (adjustable in increments of 0.1 mm)
Belt-loop width	8~20 mm (5/16"~25/32")



AP-876S



The folded pocket clothe can be made with the JEUX0021 creasing machine. These two machines work in perfect combination; for more information see 'other' section in this catalogue.



AB-1351

MOL-254

Automatic 2-needle Belt-loop Attaching Machine

The machine time is 1.2 seconds per belt-loop, which ensures increased productivity. The feed mechanism incorporates a computer controlled X-Y method to allow the operator to change the number of stitches and sewing sizes.

Model name	MOL-254
Max. sewing speed	2,500 sti/min
Number of stitches	28, 36, 42 (selectable on the operating panel)
Needle gauge	40~70 mm (1-37/64~2-3/4")
Bartacking length	7~22 mm (9/32~55/64") (adjustable in increments of 0.1 mm)
Bartacking width	1~3.2 mm (3/64~1/8") (adjustable in increments of 0.1 mm)
Belt-loop width	9~20 mm (23/64~25/32")
Finished length of belt-loop	48~78 mm (1-57/64~3-5/64")
Needle	DPx17 (#21) #19~#21



MOL-254

AMB-289

Computer-controlled, High-speed, Single-thread Chainstitch, Button-neck-wrapping Machine

The machine demonstrates the highest productivity among button neck-wrapping machines intended for men's and ladies' outer wear. A single machine unit permits the quick changeover of types of buttons to be sewn, i.e., flat buttons, shank button, marble buttons and stay buttons with a one-touch utility lever.

Model name	AMB-289
Max. sewing speed	1,800 sti/min (neck-wrapping), 1,200 sti/min (button sewing)
Button size	Sewing button without neck-wrapping: Ø8~Ø38 mm Sewing button with neck-wrapping: Ø8~Ø32 mm Counter button: Ø8~Ø25 mm
Setting data	Distance between buttonholes: 1.5~6 mm (0.1 mm step) Height of neck-wrap: 0, 1.5~10 mm
Number of data that can be input	Max. 99 patterns
Needle	SMx332EXTLG-NY (#14) #12"~#18



AMB-289

LBH-1796AN

Economy type button hole indexer workstation

The LBH-1796A is a subclass model of the LBH-1790A Series. This product is provided with a 220 mm work clamp foot. It follows the world's highest sewing speed, deeply recessed shape of the machine head and dry-head mechanism of the existing LBH-1790A. In addition, the LBH-1796A can also be used as a simplified indexer to sew three buttonholes in a row.



LBH-1796A

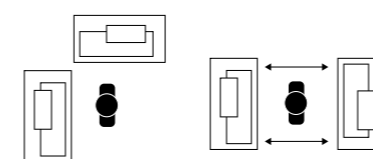

LBH-1796A
One operator operates
2 sewing machines.
14 sec./pc.

When the optionally available indexer mechanism is installed on the LBH-1796A, the operator can attend two units of this model at one time or possibly use the LK-1903B button sewing machine together with the LBH-1796A, thereby not only further increasing productivity, but also ensuring consistent product quality due to the production capability without requiring the operator to have any special skills.

Model name	LBH-1796A
Max. sewing speed	Max. 4,200 sti/min, Normal 3,600 sti/min When the non-lubricated hook (optional) is used: 3,300 sti/min
Size of cloth cutting knife	6.4~25.4 mm
Bartacking width	Max. 5.0 mm
Buttonhole length	Max. 220 mm
Lift of the work clamp	Parallel lifting 6 mm
Number of standard patterns	31 patterns
Number of patterns that can be input	Max. 99 patterns
Needle	DPx5 (#11J) #11J~#14J

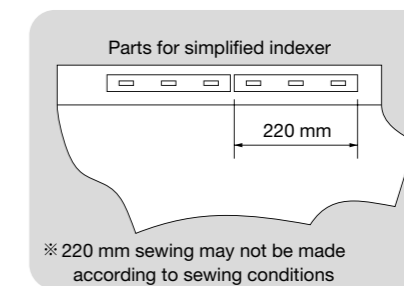

No.	Description	Part No.
1	Auxiliary carrier clamp asm	40153979
2	Laser marking lamp and LED marking lamp set.	40153980
3	Both sets together	40153978

Model name	Sewing method	Number of units to which the operator attends	Required time per shirt	Productivity
LBH-1796A	3 buttonholes	1	28 sec.	857 pcs./8 hours
	x Twice	2	14 sec.	1,714 pcs./8 hours

AC-172N-1790

High-speed, Computer-controlled Buttonholing Indexer

LBH-1790, high-speed, computer-controlled lockstitch buttonholing machine has been combined with a high-performance and highly accurate indexer.

- "Applicability to vertical stripe patterns has been improved."

The newly-developed sub-clamp mechanism prevents slippage of the material to enable accurate and consistent buttonholing.

- "Increased productivity achieved by the preset mechanism"

Model name	AC-172N-1790
Machine head	LBH-1790 (exclusive machine head for AC)
Max. sewing speed	4.200 sti/min
Sewing dimension	Standard: Width 4 mm × length 25 mm (max: width 6 mm × length 120 mm by replacing parts)
Knife size	6.4~19.1 mm (1/4"~3/4" inch)
Feed direction	Right (for men's garments) or left (for ladies' garments)
Number of patterns that can be input	20 patterns
Number of buttonholes	1~20 pcs.
Needle	DPx5 #11J~#14J

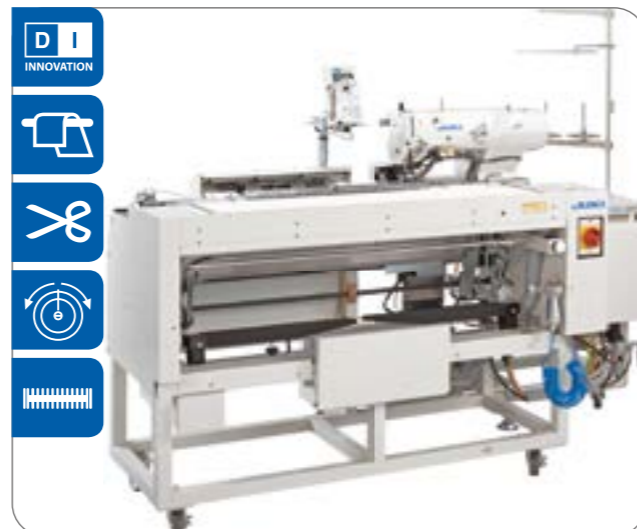

AC-172N-1790



ASN-690

Automatic Serging Machine

Increased productivity is required in the serging process. JUKI has launched its super-high speed machine developed in pursuit of simple-in-operation and ease-of-use. To fully support the operator so that he/she can carry out serging speedily, the machine comes in two different types; the long-table type and the short-table type which permits easy handling of the material.

Model name	ASN-690
Machine head	MO-6904S (super-high-speed, 1-needle overlock machine)
Application	Serging of skirts, pants, jeans, etc.
Max. sewing speed	8.000 sti/min
Stitch length	0.8~4 mm
Overedging width	4.0, 4.8, 5.6 mm
Differential feed ratio	For gathering 1:2 (max. 1:4), For stretching 1:0.7 (max. 1:0.6)
Needle	DCx27 (#11) #9~#14



ASN-690L



AE-200ALA

(join materials type)

AE-200ALD

(for sewing pin tucks)

Edge Control Seamer

The AE-200A edge control seamer is now launched. The machine is configured with JUKI's unique sensor and manipulator-control mechanisms allowing inexperienced operators to join materials with different curves with great finesses matching the finished seam quality of highly skilled operators. Sewing specifications can be quickly and accurately adjusted via touch panel to meet the requirement of various design changes and which helps operators join materials nimbly and skillfully while enhancing productivity even in sewing processes for custom-designed articles in small lots.



AE-200ALA



Model name	AE-200ALA	AE-200ALD
Machine head	DLU-5498N-7 (exclusive machine head for AE-200A)	
Sewing speed	200~3.500 sti/min	
Max. stitch length	4 mm	
Max. top-feed amount	8 mm	
Lift of the presser foot	10 mm	
Needle	DPx1 (#11) #9~#18	
Sewing condition	(seam allowance) 1~30 mm (curve sewing) 100 mm R or more (number of plies) Two or one	

WS-8700

Automatic Tag Pasting Machine

The automatic pocket pasting machine (WS-8700) is applicable to the sewing of the shirt pocket. It can realize a high-speed and stable sewing with regular and uniform pocket stitches.

Model name	WS-8700
Main Shaft Control	Servo Motor Control
Max. Sewing Speed	300 rpm
Stitch Length	1-3 mm
Air Pressure	0.5 mpa
Sewing Scope	X:200 mm Y:200 mm



WS-8700



AUTOMATIC MACHINES

Machine model	Part number	Description
APW	SP46N	Clamping-bar Stacker for APW-89#N
	SP47N	Roller Stacker for APW-89#N
	SP48	Grasp stacker for APW-89#
	SA117 (40036270)	Dart Stretcher APW-895/APW-896
	SA118S (40046271)	Shim device APW-895/APW-896
	SA119 (40052298)	Suction device APW-895/APW-896
	SA119E (40045784)	Suction device APW-895/APW-896
	SA120 (40052310)	Interlining feeder APW-895/APW-896
	SA121 (40045773)	Marking Lamp for locating flap APW-895/APW-896
	SA126 (40045778)	Bundle clamp APW-895/APW-896
	SA127 (40045779)	Suction motor for SA-119
	SA131 (40045785)	Laser Marking APW-895/APW-896
ASN	KM5 (GMC080530A0)	Cloth Table for ASN-690
	PF10 (40082454)	Differential Feed device for ASN-690
	CL5 (40082457)	Curve Sensor for ASN-690
	PK79 (40082455)	3-Pedal Unit for ASN-690 with PF-10
AC	Laser Marking (40092733)	Laser Marking for AC-172
	Cloth Edge Sensor (40098452)	Cloth Edge Sensor for AC-172
	Support Clamp (40098686)	Support Clamp for AC-172
AP	AP876JIG-A	Fold gauge + base, press and pattern plate, label insert, complete
	AP876JIG-B	Fold gauge + base, press and pattern plate, complete
	AP876JIG-C	Fold gauge, press and pattern plate, label insert
	AP876JIG-D	Fold gauge, press and pattern plate
	Barcode Reader (40119168)	Barcode Reader for AP-876
	Laser Marker (40116756)	Laser Marking for AP-876
	Garment Rack (G90118750B0)	Garment Body Rack for AP-876
	Jig Adapter (40122410)	Jig Adapter for AP-876 to use AVP-875 Jigs
AMB289	Laser Marker (40021446)	Laser Marking for AMB-289
AB	Loop Drawer (40094294)	Loop Drawer Device for AB-1351
	Pedal Sw (40090639)	Foot Pedal Activated Presser Control for AB-1351
	Third BT Cancellor (40097205)	Third Bartack Cancellation Switch AB-1351
	Laser Marker (40090637)	Laser Marker for AB-1351
MOL254	Fullness Device (G57002540A0)	Belt Loop Tension Releaser for MOL-254
	Loop Feeder (G57302540A0)	Belt Loop Feeder for MOL-254
	Air Gun (G57602540A0)	Air Gun for MOL-254
	Needle Cooler (G57702540A0)	Needle Cooler device for MOL-254
	TB Detector (G57802540A0)	Needle Thread Breakage Detector for MOL-254
AE	SS52 Clamp Bar Stacker (40088226)	Clamp Bar Stacker AE-200A
	Bobbin Monitor (40088623)	Bobbin Thread Monitor AE-200A
	2-Pedal Unit (40084064)	2-Pedal Foot Sw. Unit AE-200A
	Bobbin Winder (40088627)	Independent Bobbin Winding Device
	TB Detector (40088632)	Needle Thread Breakage Detector AE-200A





JEUX

SEAM SEALING AND ULTRASONIC MACHINES

SEAM SEALING AND ULTRASONIC MACHINES

JEUX-6510 F3+

Post-Bed, Seam Sealing Machine with Differential Speed and Memory Function

JEUX-6510 F3

Post-Bed, Seam Sealing Machine

KEY FEATURES

- Perfect solution for classic tape welding
- Appropriate for all standard tape welding operations
- Touch screen with pictograph displays
- Constant temperature profiles
- Tape cutter provided as standard
- Automatic reverse motion when stopping within seam without cutting
- Differential top and bottom feed

Model name	JEUX-6510-F3	JEUX-6510-S3+
Machine Type	Continuous even feed type	Differential top and bottom feed type
Power Consumption	AC 220V 50Hz	
Temperature	700°C (Max)	
Upper Roller Pressure	1 kg/cm ² - 2.5 kg/cm ²	
Upper Roller Diameter	65 mm	
Tape Width	Standard 12-24 mm, special width of the wheel and be ordered	



6510 F3+

JEUX-6510 S3+

Rear Angle Post-Bed, Seam Sealing Machine with Differential Speed and Memory Function

KEY FEATURES

- Perfect solution for classic tape welding
- Appropriate for all standard tape welding operations
- Touch screen with pictograph displays
- Constant temperature profiles
- Tape cutter provided as standard
- Automatic reverse motion when stopping within seam without cutting
- Differential top and bottom feed
- Rear post bed for sealing of shoes and other oddly shaped products

Model name	JEUX-6510-S3+
Machine Type	Rear angle post-bed type
Power Consumption	AC 220V 50Hz
Temperature	700°C (Max)
Upper Roller Pressure	1 kg/cm ² - 2.5 kg/cm ²
Upper Roller Diameter	65 mm
Tape Width	Standard 12-24 mm, special width of the wheel and be ordered



6510 S3+

JEUX-AI-001

Post-Bed, Seam Sealing Machine

- Stretch fabric ready
- Narrow tape ready
- Good for 3-layer taping
- Software upgradable, hardware upgradable

KEY FEATURES

- 3D Electronic nozzle positioning system
- Differential speed top/bottom roller
- Variable speed seam sealing
- Digital tensioning device
- Multi-language support
- Data memory bank
- Ergonomic

Model name	JEUX-AI-001
Power Supply	AC 220V 50/60Hz, 1Ø
Power Consumption	3600 W
Compressed Air	>0.4 Mpa
Maximum Sealing Speed	60 ft/min
Maximum Temperature	800°C
Nozzle Unit	22 mm
Upper Roller Width	25.4 mm
Lower Roller Width	31 mm
Dimensions	1200 x 750 x 1800 mm (LxWxH)
Net Weight	150 kg
Optional Roller	8-30 mm



AI-001 spec A-NNN

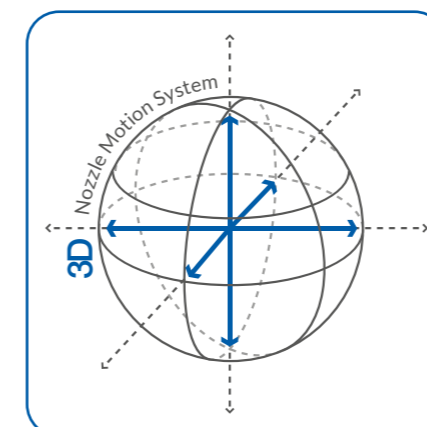

3D Nozzle Positioning

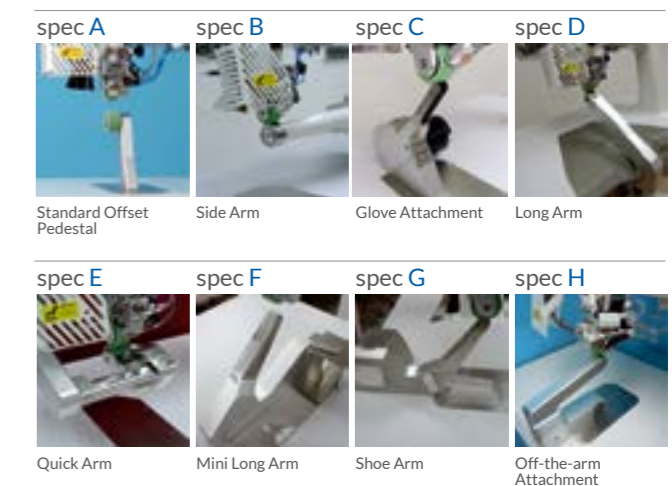

SEAM SEALING AND ULTRASONIC MACHINES

JEUX-AI-107

Rear Angle Post-Bed, Seam Sealing Machine with Differential Speed and Memory Function

- Stretch fabric ready
- Narrow tape ready
- Good for 3-layer taping
- Software upgradable

KEY FEATURES

- Differential speed top/bottom roller
- Colour touch screen interface
- Digital tensioning device
- Duplex nozzle action
- Ergonomic

Model name	JEUX-AI-107
Power Supply	AC 220V 50/60Hz, 1Ø
Power Consumption	3600 W
Compressed Air	>0.4 Mpa
Maximum Sealing Speed	60 ft/min
Maximum Temperature	800°C
Nozzle Unit	22 mm
Upper Roller Width	25.4 mm
Lower Roller Width	31 mm
Dimensions	1200 x 750 x 1800 mm (LxWxH)
Net Weight	150 kg
Optional Roller	8-30 mm



JEUX-AI-107 spec A-NNN

JEUX-AI-008

Post-Bed, Seam Sealing Machine

- Stretch fabric ready
- Multi-unit display
- All-in-one construction

KEY FEATURES

- Differential speed top/bottom roller
- Colour touch screen interface
- Digital pressure gauge

Model name	JEUX-AI-008
Power Supply	AC 220V 50/60Hz, 1Ø
Power Consumption	3600 W
Compressed Air	>0.4 Mpa
Maximum Sealing Speed	80 ft/min
Maximum Temperature	800°C
Nozzle Unit	22 mm
Upper Roller Width	25.4 mm
Lower Roller Width	31 mm
Dimensions	1200 x 750 x 1700 mm (LxWxH)
Net Weight	130 kg
Optional Roller	8-30 mm



AI-008 spec 1-NNN

QHP-A05

QHP-A08

Hot Air Sealing Machine

This hot air sealing machine uses hot air to melt specialized welding tape; the melted welding tape is then fused to the fabric as it passes through an upper and lower roller. The nozzle has been designed in such a way as to allow for extremely accurate positioning.

Model name	QHP-A08
Power required	1P/200 220 240 V 50/60Hz
Power Consumption	Abt. 2,3 KVA
Upper roller	Steel (Width: 28 mm or 30 mm/ Shape: Groove, Flat or Concave) or Silicon rubber (30 mm)
Lower roller	Silicon rubber (Width: 30 mm Shape: Flat)
Nozzle heater	2.0 KW (200V)
Nozzle width	22 mm, 24 mm, 26 mm
Nozzle air temp.	Up to 750 Centigrade
Prevention system	Power failure/Heater element/ Air pressure
Air consumption	100 liter/min.
Arm type	Post/Cylinder – one action change over



QHP-A05

LHP-PP1

Continuous Feed Heat-Sealing Machine

This bonding machine uses heat to weld fabric together using specialized seam tape. The bond created is strong and water tight after cooling. This bond can also be used on top of normal stitch seems to make them water proof. Perfectly suited for the joining of sportswear, swimwear or safety gear. Tape finishing can also be used for design purposes to give a garment a point of difference.

Model name	LHP-PP1
Power required	1P/200 220V 50/60Hz
Power Consumption	0,5 SKVA
Heat Method	Hot Plate
Arm Type	Post Type
Feed Speed	Max. 5 cm/min
Heating Temperature	Upper Heater: Max 2800°C Lower Heater: Max 1900°C
Welding Width	13 mm



LHP-PP1

SEAM SEALING AND ULTRASONIC MACHINES

JEUX-7510

Flat Bed Ultrasonic Machine

- A wide range of anvil wheels allows embossing of any profile or welding structure
- No compressed air required
- Newly developed user-interface and custom software
- Cutting and welding functions possible (S Type)
- Flat bed allows for easy and large working area
- Up to 12m/min welding speed possible

Model name	JEUX-7510-S	JEUX-7510-T
Sonotrode	Steel	Titanium
Frequency	35 kHz	
Sonotrode Standard Size	10 mm	
Actuateur Velocity	Max. 12 m/min	
User-Interface	7" touch screen	
Power Supply	230V, 50Hz	



JEUX-7510



LWU-3015

Ultrasonic Welding Sewing Machine (VARIABLE ARM SYSTEM)

The LWU-3015 is the first Ultra Sonic Welding Machine available from Juki. The machine uses ultrasonic welding of fabrics to bond them together instead of stitches. This machine creates seamless finishing's that are comfortable to wear and allow for a lot of stretchiness. Seam tape can also be used to enhance the bond (on one side) and create a water proof seal. Ultra Sonic Bonding is perfectly suited for non-woven fabric and the finishing type can create a unique point of difference for products created with this type of machine.

Model name	LWU-3015
Power Required	1P 200V 50/60Hz
Power Consumption	1,0 KVA
Power Out-Put	Max. 600 W
Oscillating Frequency	30 KHz
Feed Speed	0-8.0 m/min (minimum 0,1m/min)
Motor	2 Stepping Motors
Presser	Air Cylinder
Others	PLC Control / LCD Touch Panel / Control Horn Cooling Device / Air Pressure Detector / Welding Roller Cooling & Blowing Device Touch sensor



LWU-3015

JEUX-US-501

Sew free Ultrasonic Multi-purpose Welder

- Stretch fabric ready
- Precise trimming
- Anti-fray cut edge
- Perfect for knit and lycra
- Both straight and curve seam
- Software upgradable

KEY FEATURES

- User friendly sewing machine platform
- Ultrasonic system status indication
- Innovative auto cutter calibration
- Extremely narrow allowance
- Fabric thickness selection
- 40 kHz quiet operation
- Pattern cutting mode
- Power monitoring

Model name	JEUX-US-501
Power Supply	AC 220 V 50/60 Hz, 1Ø
Power Consumption	700 W
Ultrasonic Frequency	40 kHz
Horn Dimension	3x6 mm
Maximum Welding Speed	10 ft/min
Dimensions	1100 x 500 x 1200 mm (LxWxH)
Net Weight	120 kg



US-501

JEUX-CS-658

Pneumatic Flat Press Machine

- Colour touch screen control panel
- Consistent temperature
- Uniform pressure
- Good for all fabric
- Both hands push button activation for added safety
- Digital pressure and temperature interlock
- Flexible changeable lower platform
- Selectable foot pedal activation
- Dual time shift mode
- Top plate swing out design
- Dual counters & trend display

Model name	JEUX-CS-658
Power Supply	AC 220V 50/60Hz, 1Φ
Heater Power	1000 W
Compressed Air	>0.4 Mpa
Maximum Temperature	260°C
Timing Range	1-999 Seconds
Upper Mold Area	380 x 150 mm
Lower Mold Area	380 x 80 mm
Dimensions	710 x 780 x 830 mm (LxWxH)
Net Weight	93 kg



CS-658 spec A-D2A 1-038008

JEUX-CS-652

Pneumatic Flat Press Machine

- Consistent temperature
- Uniform pressure
- Simple to use
- Good for all fabric
- Vertical press motion
- Preset heating time
- Safety lever

KEY FEATURES

- Both hands push button activation for added safety
- Flexible changeable lower platform
- Press travel limiting device
- Optional lighting system
- Foot pedal activation

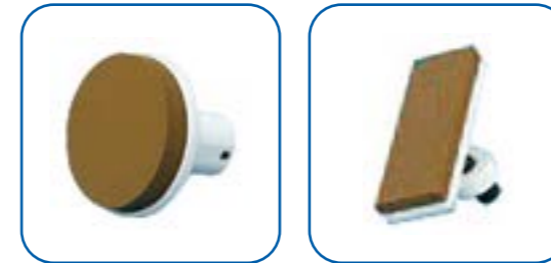

Model name	JEUX-CS-652
Power Supply	AC 220V 50/60Hz, 1Φ
Heater Power	1000 W
Compressed Air	>0.4 Mpa
Maximum Temperature	260°C
Timing Range	1-999 Seconds
Upper Mold Area	206 x 174 mm
Lower Mold Area	203 x 152 mm
Dimensions	520 x 380 x 1050 mm (LxWxH)
Net Weight	45 kg
Extra Lower Mold	150 x 50, Ø68 mm



CS-652 spec A-A 112-020015



CS-652 spec A-A1A1-020015



INDUSTRIAL PRINTERS

Sure Colour F-2100

Direct to Garment T-Shirt Printer

Every aspect of these printers, from the printer mechanism to the ink delivery system, was purpose-built to deliver industrial-level production speeds, image quality, and reliability to redefine direct-to-garment (DTG) imaging.



Sure Colour F-2100

Model	Type	Epson PrecisionCore TFP
Print speed (default)	Dual CMYK colour mode	15 sec
	Single CMYK colour mode	27 sec
	CMYK + white mode	87 sec
Max. resolution	Colour 1440 x 720 dpi, white 1440 x 1440 dpi	
Ink type	Ink cartridge capacity	UltraChrome DG ink – 600 ml
Media	100% cotton or blended materials with a minimum of 50% cotton	

Sure Colour F-6200

1 head, 111.8 cm Printing Width, Dye Sublimation Printer

Complete dye-sublimation package for creating high-quality textiles and promotional goods. The SureColour SC-F6200 is a professional digital dye sublimation roll-to-roll printer developed specifically for the production of high-quality printed textiles and promotional goods.



Sure Colour F-6200

Model	SureColour SC-F6200
Printhead configuration	PrecisionCore TFP Printhead 360 x 2 nozzles each colour (x4)
Maximum print speed	63.4 m ² /hr
2 pass print speed	30.4 m ² /hr
4 pass print speed	15.8 m ² /hr
Max pmt resolution	720 x 1440 dpi
Max. media width	1118 mm (44 inch)
Roll outer diameter	250 mm

Sure Colour F-7200

1 head, 162 cm Printing Width, Dye Sublimation Printer

The SureColour F-7200 is a professional digital dye sublimation roll-to-roll printer developed specifically for the production of high quality printed textiles. This model is perfectly suited for factories that want to bring material design in-house and the benefits of enhanced flexibility and short lead times.

Model	SureColour F-7200
Printhead configuration	PrecisionCore TFP Printhead 360 x 2 nozzles each colour (x4)
Maximum print speed	58.9 m ² /hr
2 pass print speed	30.3 m ² /hr
4 pass print speed	16.2 m ² /hr
Max print resolution	720 x 1440 cpi
Max. media width	1626 mm (64 inch)
Roll outer diameter	250 mm



Sure Colour F-7200

Sure Colour F-9300

2 head, 162 cm Printing Width, Dye Sublimation Printer

The SureColour F-9300 is ideal for fast dye-sublimation transfer printing, at speeds up to 97 sqm per hour. This innovative system includes Epsons exclusive PrecisionCore™ TFP® print heads and an integrated roll-to-roll media support system with high accuracy winding. A dye sublimation printing process allows for high definition images and patterns to be transferred onto fabric with unrivalled accuracy and clarity.

Model	SureColour F-9300
Printhead configuration	Dual PrecisionCore TFP Printhead 360 x 2 nozzles each colour (x4)
Maximum print speed	108.6 m ² /hr
2 pass print speed	60.1 m ² /hr
4 pass print speed	29.9 m ² /hr
Max print resolution	720 x 1440 dpi
Max. media width	1626 mm (64 inch)



Sure Colour F-9300



SC-922/M51N

Control Box / Servomotor

The new model control box SC-922 has been newly developed. The control box is resistant to voltage fluctuations, noise and vibration. The new model control box is provided with an energy-saving mode for the first time in a control box for sewing machines. Power consumption during standby period is further reduced. Considering convenience in setup and resource saving, both the volume and the weight of the control box has been reduced by 30% or more (as compared with the conventional control box SC-510).

High-torque AC servomotor M51N with an output of 750W has been adopted. The machine has excellent high-speed sewing performance and a strong cloth-penetrating force. The machine therefore demonstrates a broader range of applicability, from general fabric to extra heavy-weight materials.



SC-922/M51N

Model name	SC-922/M51N
Motor output	750 W
Power requirement	Single-phase 100~120V, 200~240V 3-phase 200~240V
Number of input ports	Max. 24 ^{*1} (for optional inputs)
Number of output ports	Max. 32 ^{*1} (for optional outputs)
Number of basic programs ^{*2}	4
Number of basic programs steps	25 sewing steps (per 1 program)

^{*1} It depends on installed machine head.

^{*2} Basic programs are intended to operate external devices such as the stacker or to change the sewing machine operation during sewing.

SC-920/M92

The control box is resistant to voltage fluctuations, noise and vibration. The control box is provided with an energy saving mode reducing the power consumption during operation and standby. Considering convenience in setup and resource saving, both the volume and the weight of the control box have been reduced by 30%. High-torque AC servomotor M92 with an output of 450W has been adopted. This model is perfectly suited for apparel production and allows for programmable input through an operational panel (sold separately).



SC920/M92

SV-71

SV-72

Servo Motor

This is a highly effective, light weight (4.5 kg) servo motor has a digital display and flexible function control. The SV-72 comes with 2 output ports

Function	SV-71	SV-72
Input Voltages Ranges	220V±10%	
Motor Output Power	450W / 650W	
Output Ports	1	2
Motor Rated Speed	5000 RPM	
Pulley Size Range	50-100 mm	



SV-71

SV-82

Servo Motor

This servo motor is available with both 350W and 650W power options and is perfectly suited for Overlock sewing Machines.

Function	SV-82
Input Power Voltages	Single Phase 220V
Motor Output Power	350W / 650W
Motor Rated Speed	7000 / 3500RPM



SV-82

SV-520

Programmable Servo Motor

This programmable servo motor is available in 350W or 650W and is best suit to Juki's MO Series as well as Juki's MF series (650W).

Function	SV-520	SV-550
Input Power Voltages	Single Phase 220V	
Motor Output Power	350 / 550 / 750W	450W~750W
Motor Rated Speed	35000 / 5000RPM	
Pulley Size Range	65-100 mm	



SV-520

Motors and Control Boxes

	Descriptions	Item Number
Motors	300W-INDUCTION MOTOR	FIR 300W Induction Motor (3Ph)
	370W CLUTCH MOTOR	FIR 370W Clutch Motor
	550W CLUTCH MOTOR	FIR 550W Clutch Motor (380V 3ph)
	NS412	ISM 400W Clutch Motor: NS-412, (220V 1ph)
	NS432	ISM 400W Clutch Motor: NS-432, (380V 3ph)
	CLUTCH MOTOR 400W, 220V WITH SWITCH	400W Clutch Motor, (220V 1ph)
	INDUCTION MOTOR 300W, 220V WITH SWITCH	300W Induction Motor, (220V 1ph)
Servomotors	M51N	SC921/SC922 servo motor
	M92	SC920 servo motor
Control-Boxes	SC910NNA	SC910N control box
	SC910NNS	SC910N control box
	SC920AN	SC920 control box
	SC920CN	SC920 control box
	SC921AN	SC921 control box
	SC921BN	SC921 control box
	SC921CN	SC921 control box
	SC922AN	SC921 control box

JEUX-0021

Creasing machine for pockets

For creasing pockets with high pressure and temperature without the pocket works being damaged, with two creasing units that bring high productivity. The inner edge can be folded inwards to avoid overlapping of fabric. Pressure and temperature are adjustable. Thermostats keep pressing temperatures and time constant.



JEUX-0021





Terminals positioned at each workstation are designed to monitor, track and report the entire breadth of your production floor activities. Significantly improving production balance, supply chain visibility and manufacturing cycle times. These terminals allow the entire factory to communicate quickly and effectively reducing the time it takes to react to problems and carry out administrative work. JaNets works to convert unproductive time into productive time or in other words increase efficiency.

This conversion allows for an increased output or for a factory to produce the same amount with less labor and/or working hours. If management are given data to see exactly when, where and why an operator stops sewing (going off-standard) then they can work to eliminate or reduce this. Time spent doing menial administrative work is streamlined allowing line managers to spend their time on the floor. Communication between operators, line managers, engineering and management is also made more efficient reducing non productive work hours.



Return on investment

As JaNets works to improve a factories over all efficiency the return of your investment can happen extremely fast. Excluding the functional benefits listed above JaNets will reduce unproductive and wasted time meaning that a factory is continuously improving its output for a lower cost. JaNets is suited for many different production sizes and is not limited to large factories with many operators; the system is just as impactful in smaller factories where the most effective production process is needed to glean as much of an advantage as possible.

The typical return on investment for a medium sized factory that has implemented JaNets is just 12-24 months.

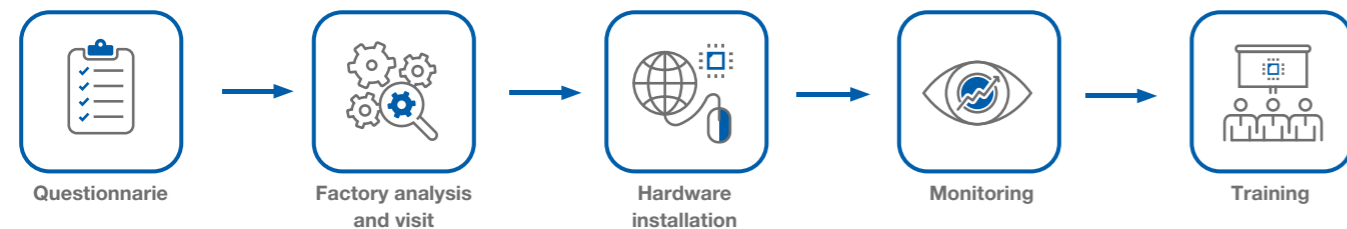

PM-1

Programming Software for Computer-controlled Sewing Machines

This software is to input and edit sewing data of JUKI's latest sewing machines. Its versatile input functions allow to input sewing data of each electronic sewing machine model easily, accurately, and quickly. It supports high quality production with high added value by utilizing and creating original data for specific designs and applications.

System Formation

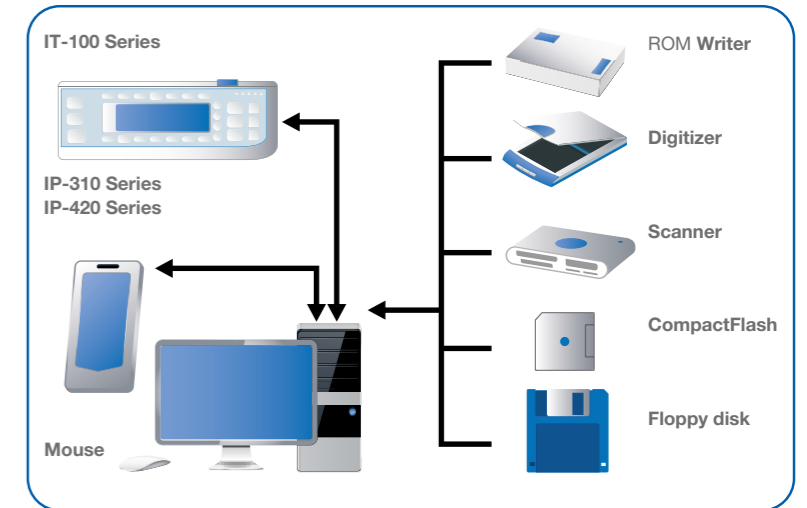

*The IP-420 is configured with a USB connector, as standard.

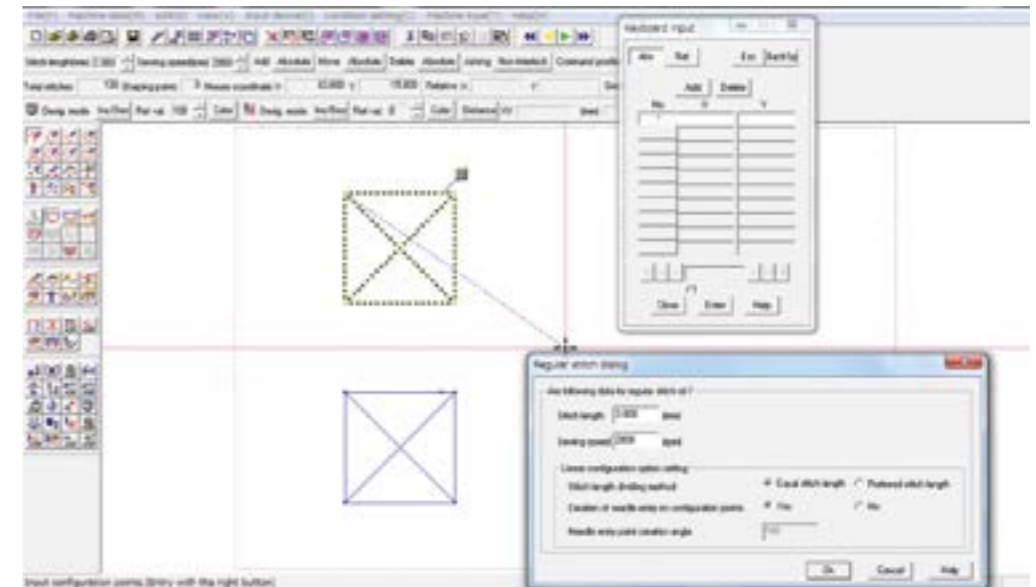

Models suited for PM-1

- AMS series
- LK-1900 series
- LK-1900A series
- LK-1900AN series
- LK-1900B series
- LK-1910, LK-1920
- LK-1930 series
- LZ-2290A series
- LBH-1790
- LBH-1790A
- MB-1800
- AVP-875

CompactFlash™ or CFA specification compatible media. CompactFlash™ is a registered trademark of SanDisk Corporation, U.S.A. Other company names and product names/brand names are trademarks or registered trademarks of the respective companies.

PM-3

Programming Software for Computer-controlled Sewing Machines

This software is developed exclusively for creating embroidery data. With the software, the operator is able to enter/edit new/existing data. Embroidery data can be easily created simply by inputting the character to be embroidered, selecting the font and clicking the relevant icon. Not only enlargement/reduction in size, rotation, move and copy of the characters, but also changes in sewing pitch and stitching order and the insertion of thread trimming can be carried out with ease. It is also possible to read images through the scanner to create data on embroidery (single pattern embroidery). True Type Fonts prepared by Windows are also applicable. The sewing machine supports three different languages; English, Chinese and Japanese.

